

## SLIDING AUTOMATIC DRIVE SYSTEMS: DURA-GLIDE™ ALL GLASS, BI-PARTING

### 1.14 - BI-PARTING WITH NO BREAKOUT

- 1.14.01 - BI-PARTING, NO BREAKOUT
- 1.14.02 - BI-PARTING WITH AUTOMATIC LOCKING, NO BREAKOUT



# DURA-GLIDE INTERNATIONAL ALL GLASS

<b>BI-PART ALL GLASS</b>	
PROJECT INFORMATION	
PROJECT NAME:	
LOCATION:	
DOOR NUMBER(S):	
DATE:	SHEET: OF

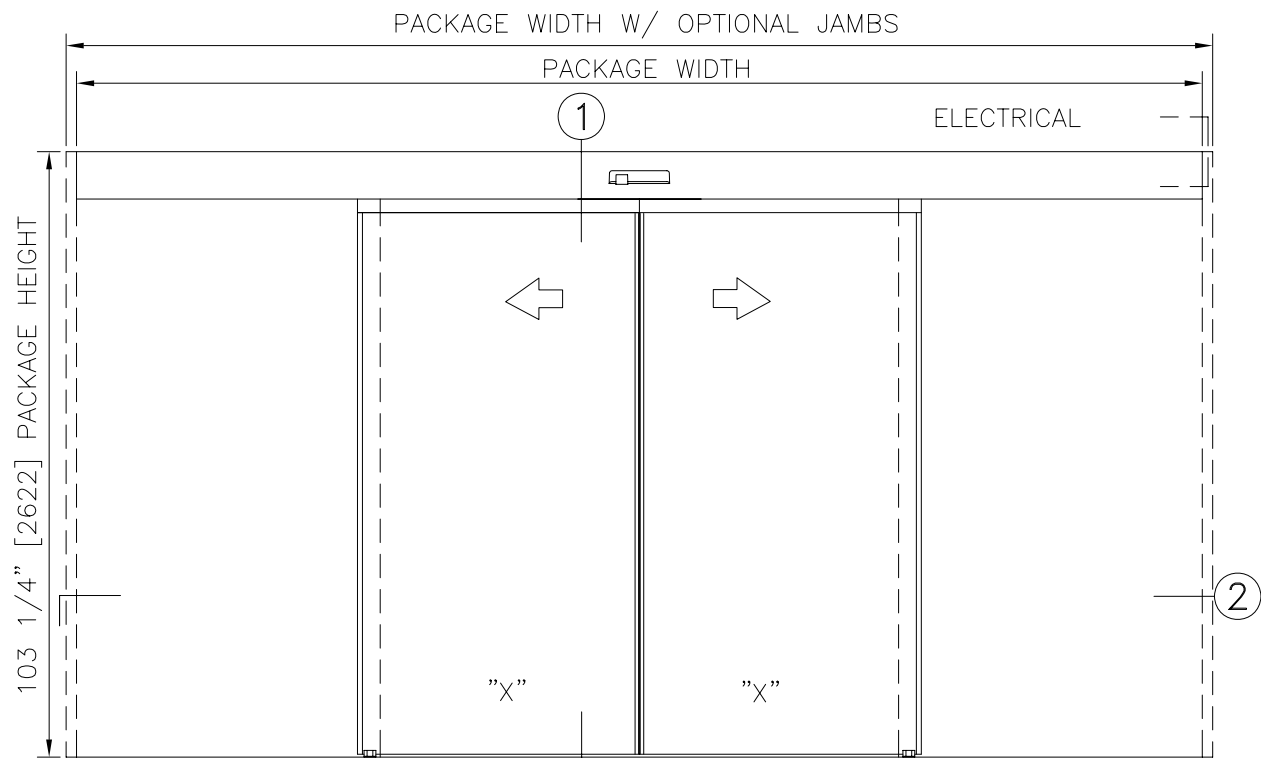

**ELEVATION VIEW**  
SCALE: 3/8" = 1'-0"

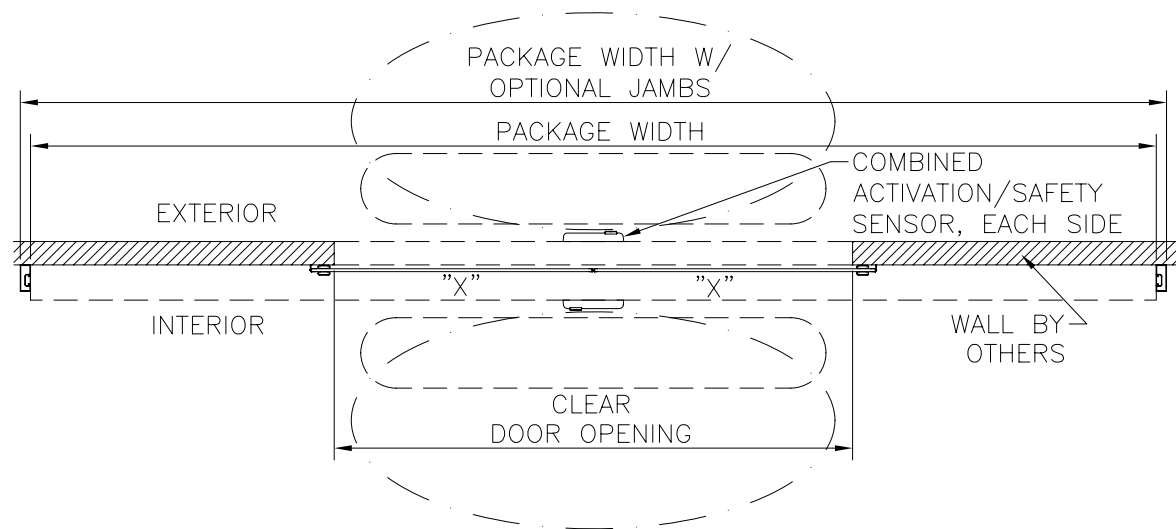

**PLAN VIEW**  
SCALE: 3/8" = 1'-0"

**NOTES**

- ELECTRICAL REQUIREMENTS: 120 VAC, 5 AMP, OR 240 VAC 2.5 AMP, MIN TO POWER OPERATOR BY ELECTRICAL CONTRACTOR.
- STANDARD GLAZING IS 1/2" [12.7]; SEE AVAILABLE OPTIONS UNDER "PRODUCT OPTIONS". COORDINATE WITH ADJ. FLOOR GUIDE.
- STANDARD INSTALLATION EXCLUDES JAMB TUBES; 4 1/2" [114] AND 6" [152] AVAILABLE.
- LIMITS OF ACTIVATION AND SAFETY ZONES ARE FOR REFERENCE ONLY; SEE ANSI/BHMA A156.10 FOR DETAILED REQUIREMENTS.
- MAXIMUM SENSOR OFFSET FOR COMPLIANCE WITH ANSI/BHAM A156.10 IS 10 5/8" [270] AT PACKAGE HEIGHT OF 92" [2337].
- SEE SPECIFICATIONS FOR ADDITIONAL INFORMATION.

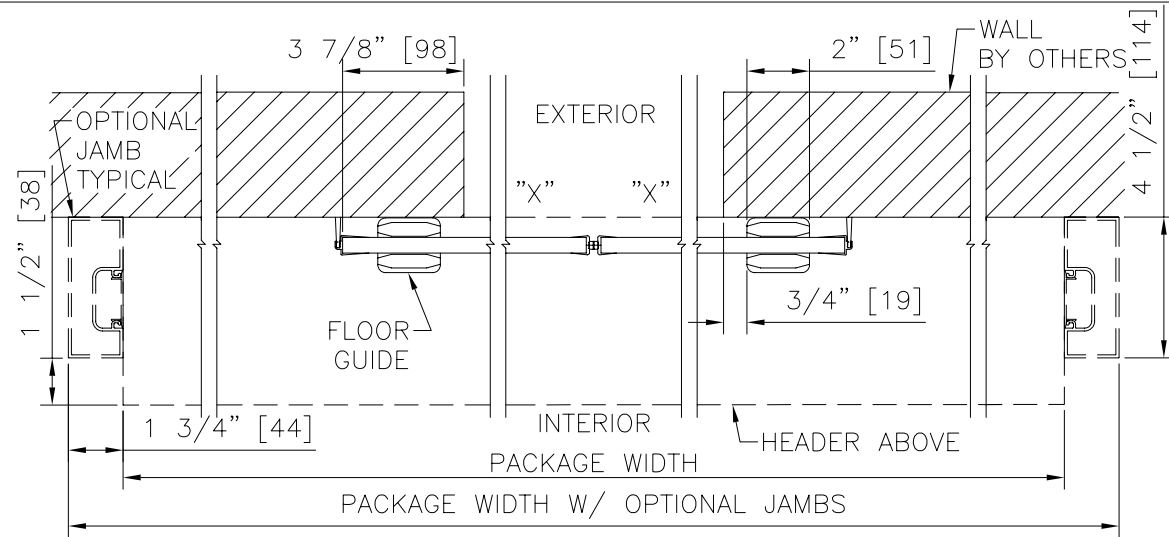

**② HORIZONTAL SECTION**  
SCALE: 2" = 1'-0"

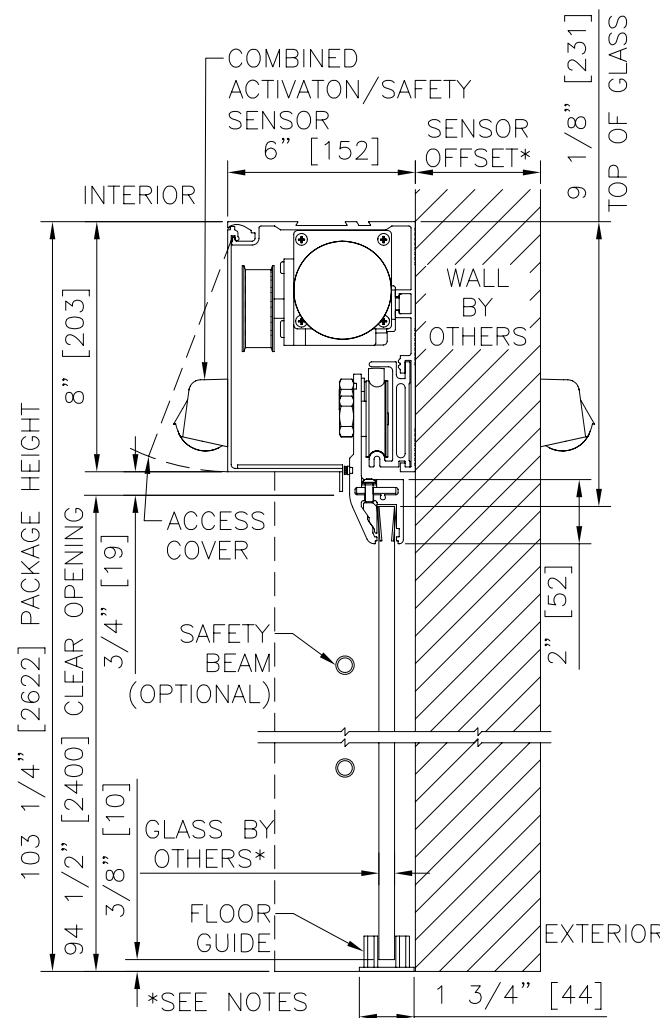

**① VERTICAL SECTION**  
SCALE: 2" = 1'-0"

**PRODUCT OPTIONS**

- FINISH**
- ANODIZED CLEAR CL2
  - ANODIZED DK BRONZE
- LOCKING**
- NONE
  - SOLENOID LOCK SECURE (AUTOMATIC)
  - SOLENOID LOCK SAFE (AUTOMATIC)
- GLASS**
- 12 mm [0.47"]
  - 10 mm [0.39"]
  - 1/2" [12.7]
  - 3/8" [9.5]
- JAMBS**
- NONE (STD)
  - 4 1/2" [114]
  - 6" [152]
- ACTIVATION/SAFETY**
- NONE
  - 2 WIZARD
  - 2 WIZARD + 2 BEAMS
- POWER SUPPLY**
- 120 VAC, 5 AMP
  - 240 VAC, 2.5 AMP
- OTHER OPTIONS**
- ROCKER CONTROL SWITCH
  - ROTARY CONTROL SWITCH
  - UNINTERRUPTIBLE POWER SUPPLY
  - FLY OPEN BOX
  - KEYED

**BI-PART FORMULAS (WITHOUT OPTIONAL JAMBS)**  
 PACKAGE WIDTH = 2 X CLEAR DOOR OPENING + 15.25" [387]  
 CLEAR DOOR OPENING = 1/2 PACKAGE WIDTH - 7.63" [194]  
 DOOR PANEL WIDTH = 1/4 PACKAGE WIDTH + 0.063" [1.6]

WITH JAMBS ADD 3.50" [89] TO PACKAGE WIDTH.

TYPICAL PACKAGE DIMENSIONS (WITHOUT OPTIONAL JAMBS)		
PACKAGE WIDTH	NOMINAL CLEAR DOOR OPENING	DOOR PANEL NOMINAL WIDTH
120.0" [3048]	52.4" [1330]	30.1" [764]
144.0" [3658]	64.4" [1635]	36.1" [916]
168.0" [4267]	76.4" [1940]	42.1" [1068]
192.0" [4877]	88.4" [2245]	48.1" [1221]
216.0" [5486]	100.4" [2550]	54.1" [1373]

**BI-PART ALL GLASS NON-BREAKOUT**

**DURA-GLIDE INTERNATIONAL ALL GLASS**

**DURA-GLIDE  
INTERNATIONAL  
ALL GLASS**

BI-PARTING

PROJECT INFORMATION

PROJECT NAME:

LOCATION:

DOOR NUMBER(S):

DATE:

SHEET: OF

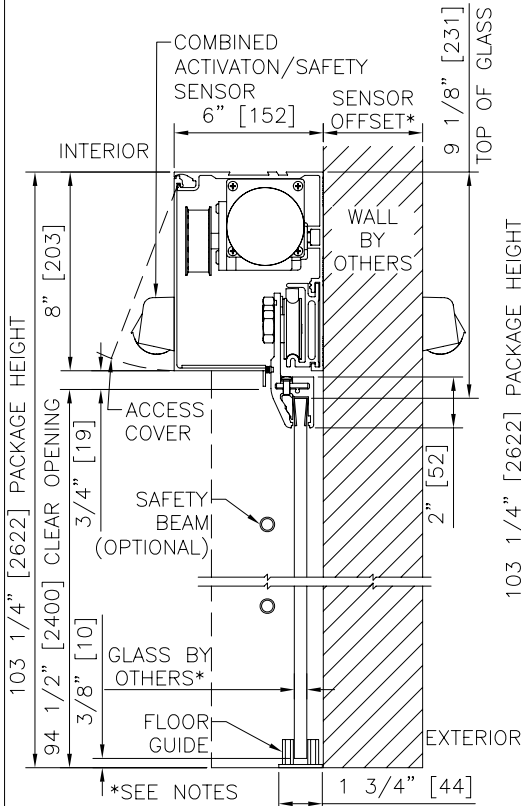

1 VERTICAL SECTION

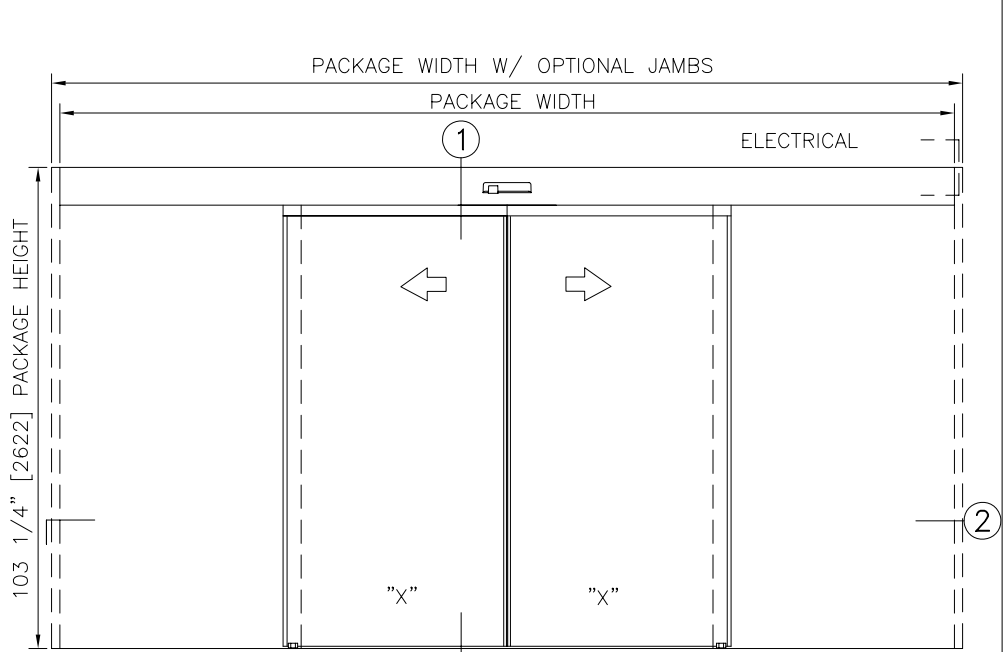

ELEVATION

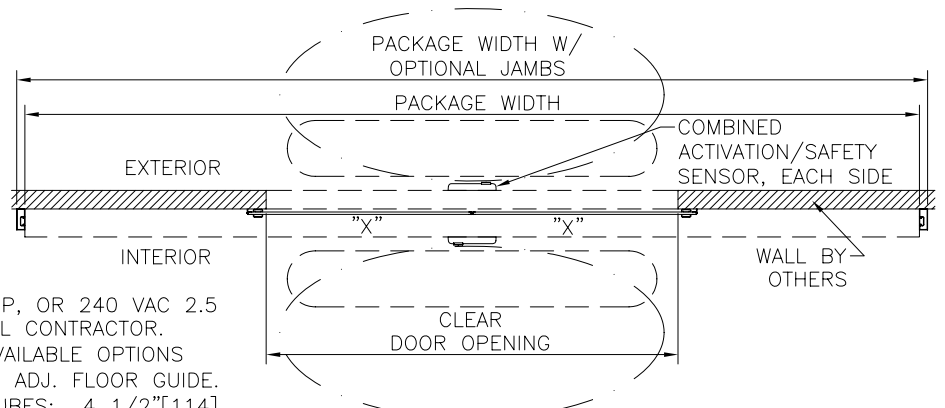

PLAN

NOTES

1. ELECTRICAL REQUIREMENTS: 120 VAC, 5 AMP, OR 240 VAC 2.5 AMP, MIN TO POWER OPERATOR BY ELECTRICAL CONTRACTOR.
2. STANDARD GLAZING IS 1/2" [12.7]; SEE AVAILABLE OPTIONS UNDER "PRODUCT OPTIONS". COORDINATE WITH ADJ. FLOOR GUIDE.
3. STANDARD INSTALLATION EXCLUDES JAMB TUBES; 4 1/2" [114] AND 6" [152] AVAILABLE.
4. LIMITS OF ACTIVATION AND SAFETY ZONES ARE FOR REFERENCE ONLY; SEE ANSI/BHMA A156.10 FOR DETAILED REQUIREMENTS.
5. SEE SPECIFICATIONS FOR ADDITIONAL INFORMATION.

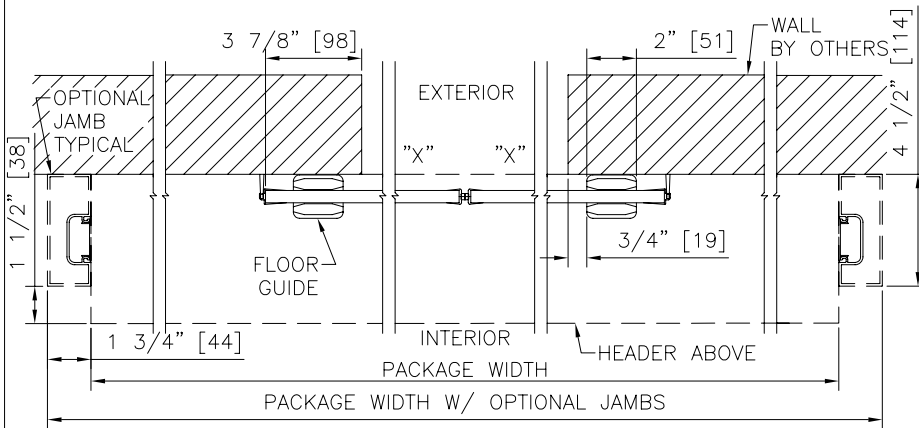

2 HORIZONTAL SECTION

TYPICAL PACKAGE DIMENSIONS  
(WITHOUT OPTIONAL JAMBS)

PACKAGE WIDTH	NOMINAL CLEAR DOOR OPENING	DOOR PANEL NOMINAL WIDTH
120.0"[3048]	52.4"[1330]	30.1"[764]
144.0"[3658]	64.4"[1635]	36.1"[916]
168.0"[4267]	76.4"[1940]	42.1"[1068]
192.0"[4877]	88.4"[2245]	48.1"[1221]
216.0"[5486]	100.4"[2550]	54.1"[1373]

## DURA-GLIDE INTERNATIONAL ALL GLASS

BI-PARTING WITH AUTOMATIC LOCKING

PROJECT INFORMATION

PROJECT NAME:

LOCATION:

DOOR NUMBER(S):

DATE:

SHEET: OF

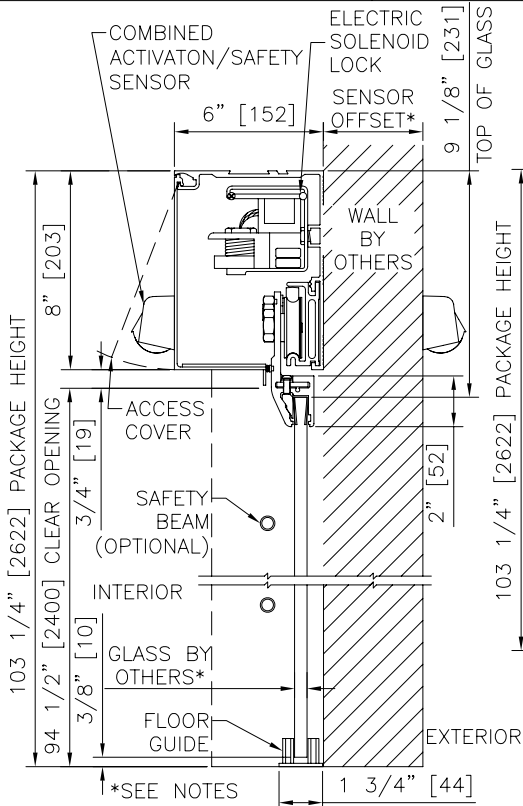

1 VERTICAL SECTION

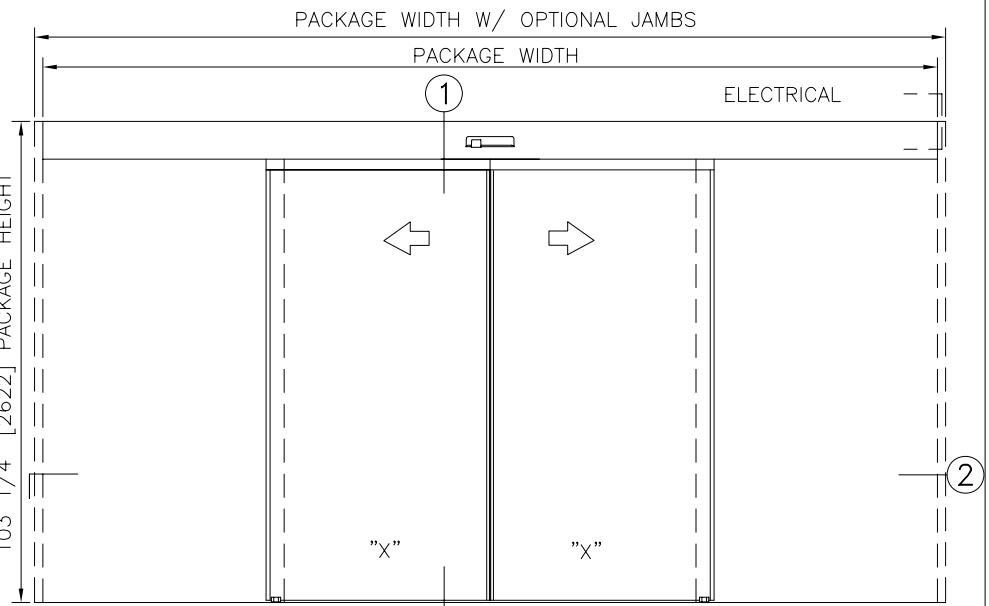

ELEVATION

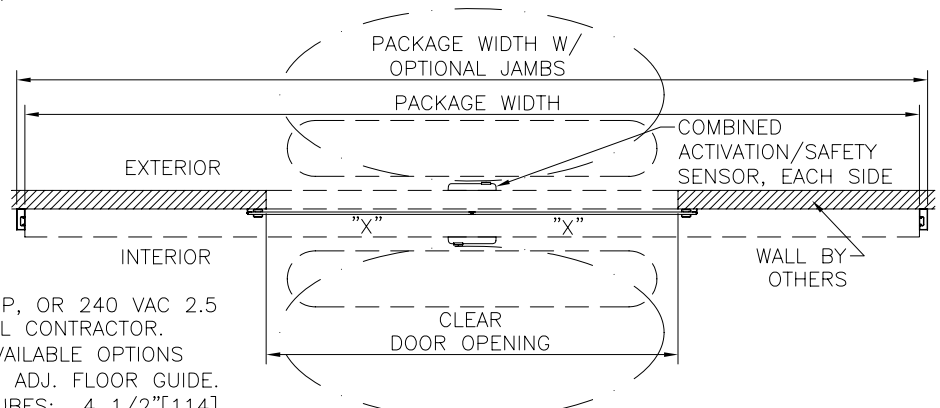

PLAN

NOTES

1. ELECTRICAL REQUIREMENTS: 120 VAC, 5 AMP, OR 240 VAC 2.5 AMP, MIN TO POWER OPERATOR BY ELECTRICAL CONTRACTOR.
2. STANDARD GLAZING IS 1/2" [12.7]; SEE AVAILABLE OPTIONS UNDER "PRODUCT OPTIONS". COORDINATE WITH ADJ. FLOOR GUIDE.
3. STANDARD INSTALLATION EXCLUDES JAMB TUBES; 4 1/2" [114] AND 6" [152] AVAILABLE.
4. LIMITS OF ACTIVATION AND SAFETY ZONES ARE FOR REFERENCE ONLY; SEE ANSI/BHMA A156.10 FOR DETAILED REQUIREMENTS.
5. SEE SPECIFICATIONS FOR ADDITIONAL INFORMATION.

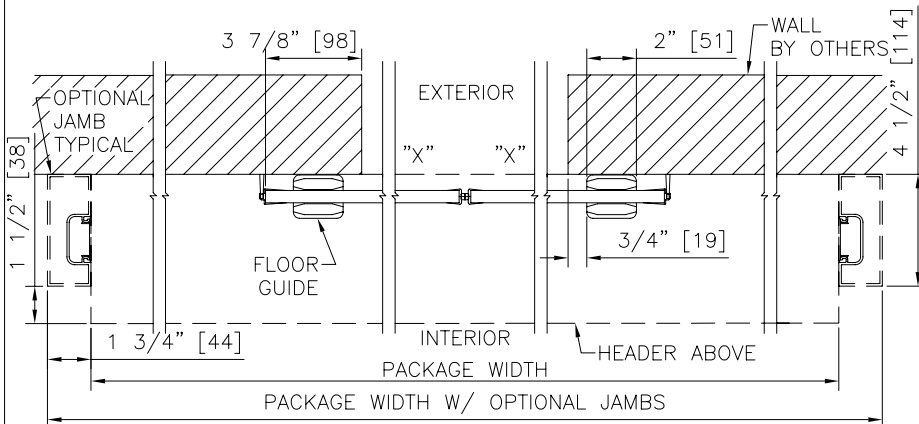

2 HORIZONTAL SECTION

TYPICAL PACKAGE DIMENSIONS (WITHOUT OPTIONAL JAMBS)

PACKAGE WIDTH	NOMINAL CLEAR DOOR OPENING	DOOR PANEL NOMINAL WIDTH
120.0" [3048]	52.4" [1330]	30.1" [764]
144.0" [3658]	64.4" [1635]	36.1" [916]
168.0" [4267]	76.4" [1940]	42.1" [1068]
192.0" [4877]	88.4" [2245]	48.1" [1221]
216.0" [5486]	100.4" [2550]	54.1" [1373]