



SLIDING AUTOMATIC ENTRANCES: DURA-STORM™ 3000, SINGLE SLIDE

2.08 - SINGLE SLIDE WITH OPTIONAL TRANSOM

- **2.08.01 - Single Slide Right Hand**
- **2.08.02 - Single Slide Left Hand**
- **2.08.03 - Single Slide Right Hand with Panic Release**
- **2.08.04 - Single Slide Left Hand with Panic Release**
- **2.08.05 - Single Slide Right Hand with Transom**
- **2.08.06 - Single Slide Left Hand with Transom**
- **2.08.07 - Single Slide Right Hand with Panic Release & Transom**
- **2.08.08 - Single Slide Left Hand with Panic Release & Transom**
- **2.08.09 - Single Slide Right Hand with Automatic Locking**
- **2.08.10 - Single Slide Left Hand with Automatic Locking**
- **2.08.11 - Single Slide Right Hand with Panic Release & Automatic Locking**
- **2.08.12 - Single Slide Left Hand with Panic Release & Automatic Locking**
- **2.08.13 - Single Slide Right Hand with Transom & Automatic Locking**
- **2.08.14 - Single Slide Left Hand with Transom & Automatic Locking**
- **2.08.15 - Single Slide Right Hand with Panic Release, Transom & Automatic Locking**
- **2.08.16 - Single Slide Left Hand with Panic Release, Transom & Automatic Locking**

STANLEY
Access Technologies

DURA-STORM
3000
NON-IMPACT
SERIES

SINGLE SLIDE WITH OPTIONAL TRANSOM
PROJECT INFORMATION

PROJECT NAME:	
LOCATION:	
DOOR NUMBER(S):	
DATE:	SHEET: OF

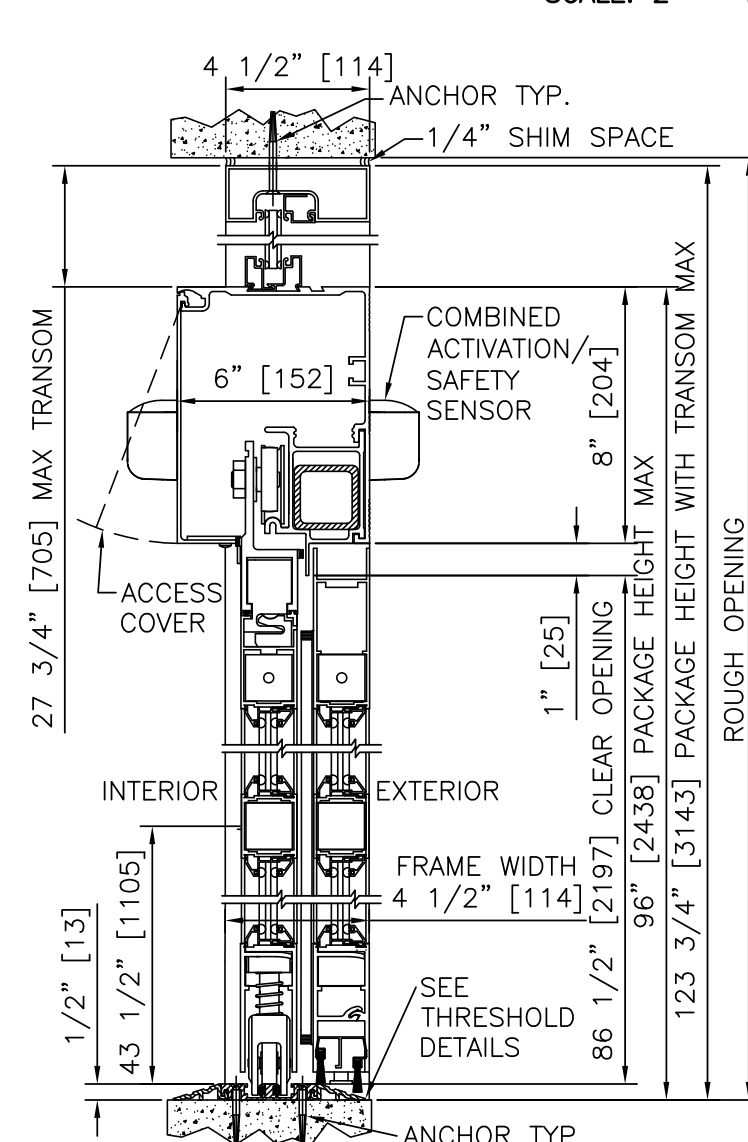
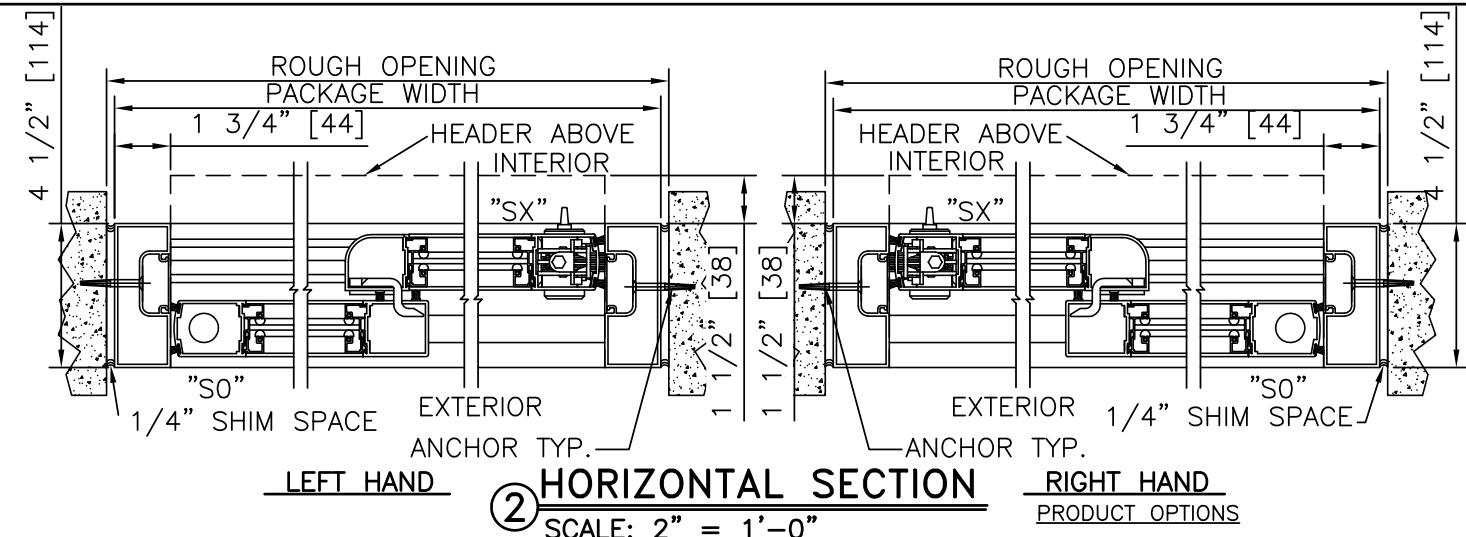
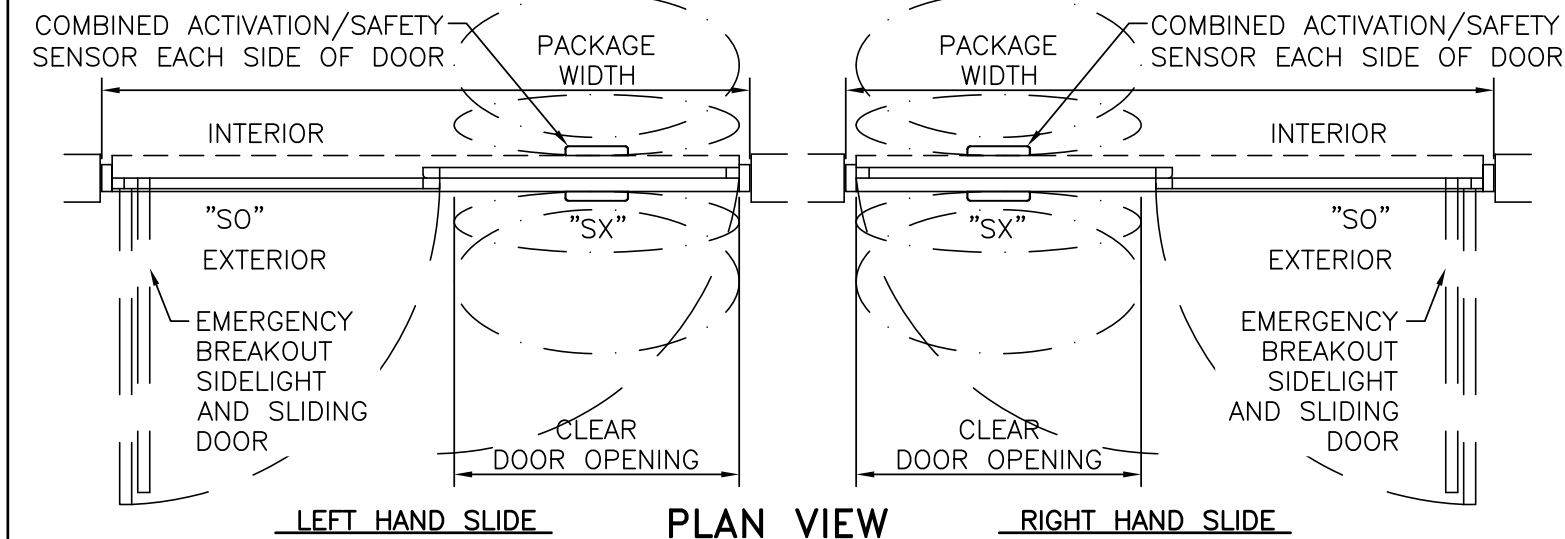
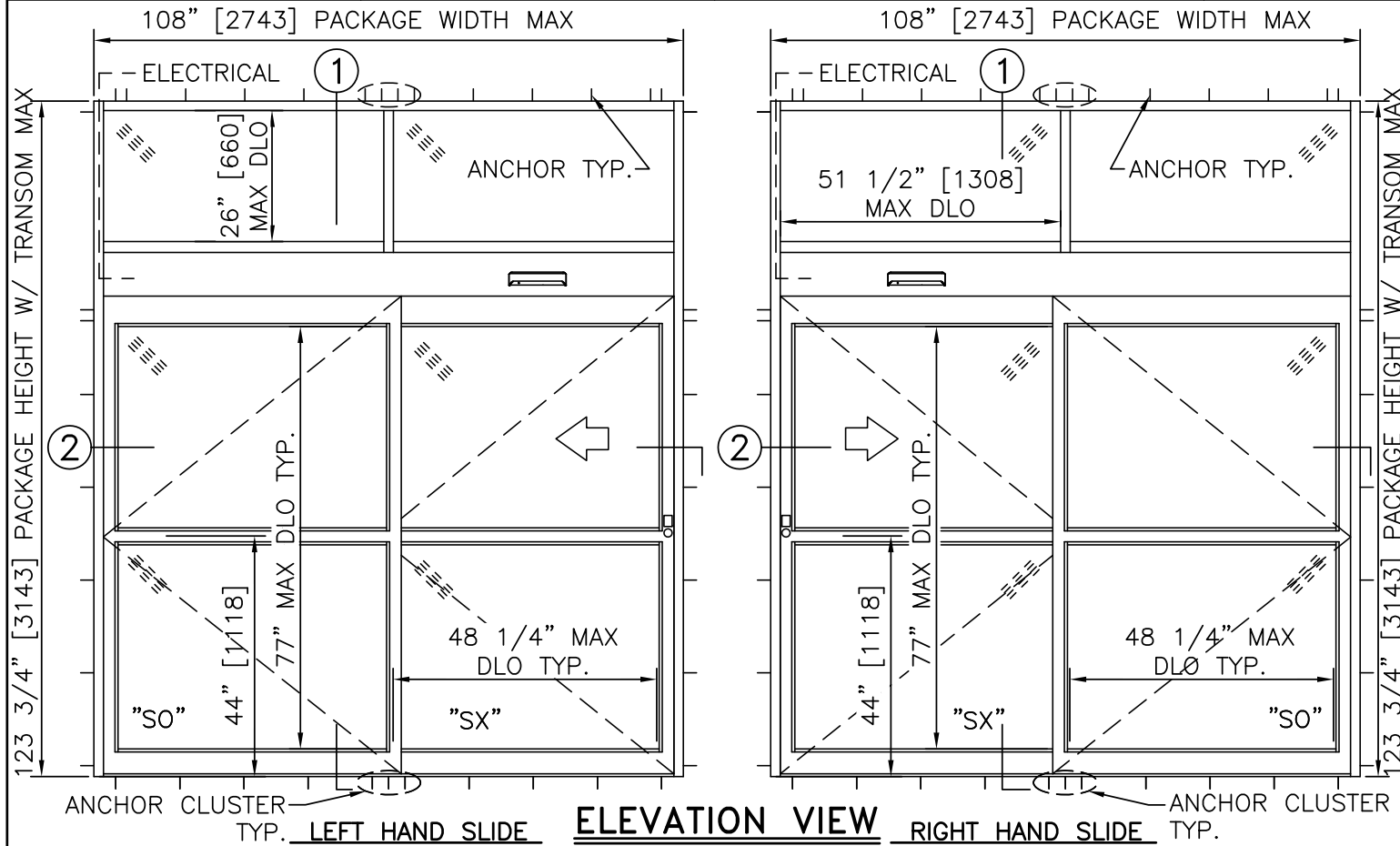

- FINISH**
- ANODIZED CLEAR CL2
 - ANODIZED DK BRONZE
 - CUSTOM
- LOCKING**
- 3-POINT
 - 2-POINT W/ PANIC RELEASE
 - ELECTRIC SOLENOID LOCK
- STILES**
- NARROW
 - MEDIUM
- MUNTINS**
- 2"
 - 4 1/4"
 - NONE
- JAMBS**
- 4 1/2"
 - 6"
- BOTTOM RAILS**
- STANDARD 4"
 - OPTIONAL 6" 8" 10"
- THRESHOLDS**
- SQ/BVL (EXT)
 - SQ/BVL (INT)
 - DBL BVL
 - RECESSED
- ACTIVATION/SAFETY**
- 2 COMBINED ACTIVATION/SAFETY SENSORS
- OTHER OPTIONS**
- ROTARY CTRL SWITCH
 - KEYED
 - UNINTERRUPTIBLE POWER SUPPLY
 - FLY OPEN BOX
 - WIND DAMPERS
 - ALARM CONTACTS

MAX. PACKAGE DIMENSIONS (NARROW STILE)			
PACKAGE WIDTH	NOMINAL CLEAR DOOR OPENING	DOOR PANEL NOMINAL WIDTH	EMERGENCY BREAKOUT NOM. WIDTH
108"	47.3"	53.5"	99.0"

DESIGN RATINGS	
MISSILE IMPACT RATING	
N/A	LARGE AND SMALL MISSILE IMPACT
DESIGN PRESSURE RATING (PSF[Pa])	
POSITIVE	55 PSF [2633 Pa]
NEGATIVE	55 PSF [2633 Pa]

SINGLE SLIDE FORMULAS - NARROW STILE
 PACKAGE WIDTH = 2 X CLEAR DOOR OPENING + 13.4"
 CLEAR DOOR OPENING = 1/2 PACKAGE WIDTH - 6.7"
 EMERGENCY BREAKOUT WIDTH = PACKAGE WIDTH - 9.0"
 DOOR PANEL WIDTH = 1/2 PACKAGE WIDTH - 0.5"

SINGLE SLIDE FORMULAS - MEDIUM STILE
 PACKAGE WIDTH = 2 X CLEAR DOOR OPENING + 17.8"
 CLEAR DOOR OPENING = 1/2 PACKAGE WIDTH - 8.9"
 EMERGENCY BREAKOUT WIDTH = PACKAGE WIDTH - 10.5"
 DOOR PANEL WIDTH = 1/2 PACKAGE WIDTH + 0.2"

SINGLE SLIDE WITH OPTIONAL TRANSOM

DURA-STORM
3000
NON-IMPACT
SERIES

STANLEY
Access Technologies

- NOTES**
- ELECTRICAL REQUIREMENTS: 120 VAC, 5 AMP MIN TO POWER OPERATOR BY ELECTRICAL CONTRACTOR.
 - ROUGH OPENING SHALL PROVIDE 1/4"[6] SHIM SPACE ON SIDES AND TOP OF PACKAGE.
 - ACTIVATION AND SAFETY ZONES ARE FOR REFERENCE ONLY; SEE ANSI/BHMA A156.10 FOR DETAILED REQUIREMENTS.
 - 5-POINT LOCKING STANDARD. ELECTRIC SOLENOID LOCK MAY BE ADDED FOR ACCESS CONTROL.
 - STANDARD GLAZING STOPS FOR SLIDING PANELS, FIXED PANELS, AND TRANSOMS ARE 1/4"[6]; 1"[25] AVAILABLE.
 - STANDARD STILES, BOTTOM RAILS AND MUNTINS SHOWN; MEDIUM STILES, BOTTOM RAILS TO 10"[254], AND 4 1/4"[108] MUNTINS AVAILABLE.
 - PRODUCT SHALL BE MANUFACTURED AND INSTALLED IN ACCORDANCE WITH PRODUCT APPROVALS; SEE MIAMI-DADE COUNTY NOTICE OF ACCEPTANCE OR FLORIDA BUILDING CODE APPROVAL
 - SEE SPECIFICATIONS FOR ADDITIONAL INFORMATION.

**DURA-STORM
3000
NON-IMPACT
SERIES**

SINGLE SLIDE RIGHT HAND

PROJECT INFORMATION

PROJECT NAME:

LOCATION:

DOOR NUMBER(S):

DATE:

SHEET: OF

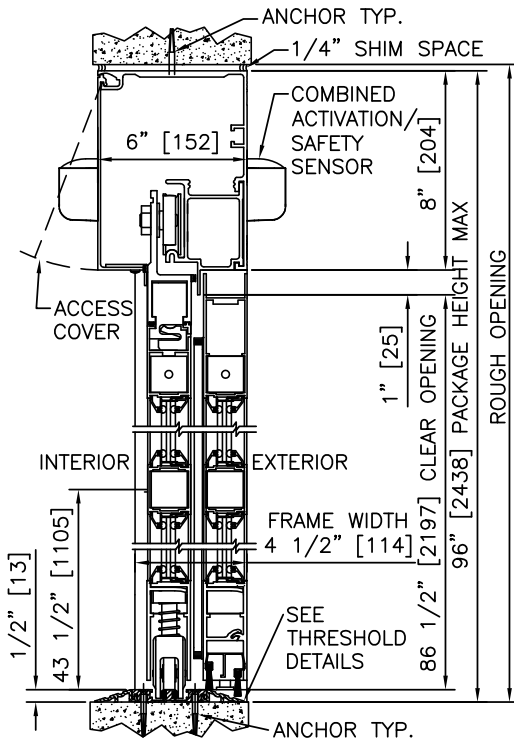

① VERTICAL SECTION

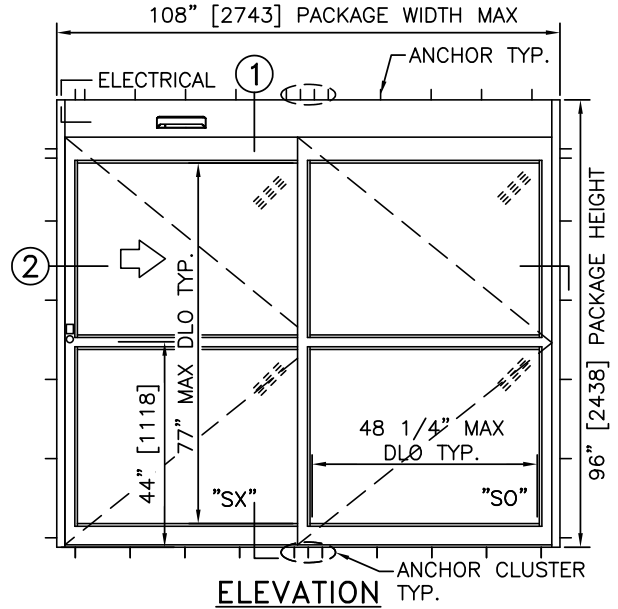

ELEVATION

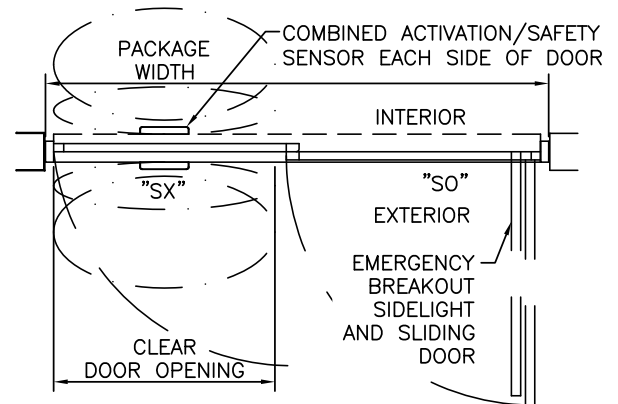

PLAN

NOTES

1. ELECTRICAL REQUIREMENTS: 120 VAC, 5 AMP MIN TO POWER OPERATOR BY ELECTRICAL CONTRACTOR.
2. ROUGH OPENING SHALL PROVIDE 1/4"[6] SHIM SPACE ON SIDES AND TOP OF PACKAGE.
3. ACTIVATION AND SAFETY ZONES ARE FOR REFERENCE ONLY; SEE ANSI/BHMA A156.10 FOR DETAILED REQUIREMENTS.
4. PRODUCT SHALL BE MANUFACTURED AND INSTALLED IN ACCORDANCE WITH PRODUCT APPROVALS; SEE MIAMI-DADE COUNTY NOTICE OF ACCEPTANCE OR FLORIDA BUILDING CODE APPROVAL
5. SEE SPECIFICATIONS FOR ADDITIONAL INFORMATION.

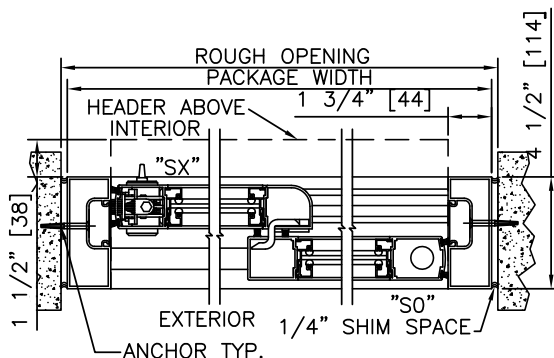

② HORIZONTAL SECTION

MAX. PACKAGE DIMENSIONS (NARROW STILE)			
PACKAGE WIDTH	NOMINAL CLEAR DOOR OPENING	DOOR PANEL NOMINAL WIDTH	EMERGENCY BREAKOUT NOM. WIDTH
108"	47.3"	53.5"	99.0"

DESIGN RATINGS	
MISSILE IMPACT RATING	
N/A	LARGE AND SMALL MISSILE IMPACT
DESIGN PRESSURE RATING (PSF [Pa])	
POSITIVE	55 PSF [2633 Pa]
NEGATIVE	55 PSF [2633 Pa]

**DURA-STORM
3000
NON-IMPACT
SERIES**

SINGLE SLIDE LEFT HAND
PROJECT INFORMATION

PROJECT NAME:
LOCATION:
DOOR NUMBER(S):
DATE: SHEET: OF

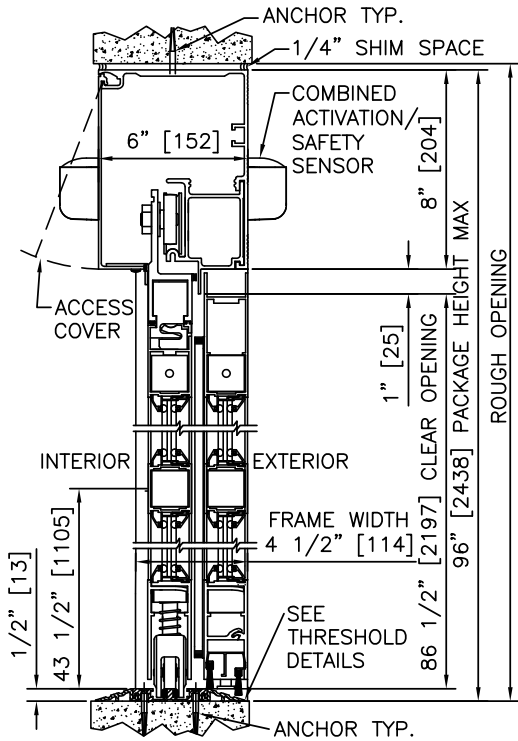

1 VERTICAL SECTION

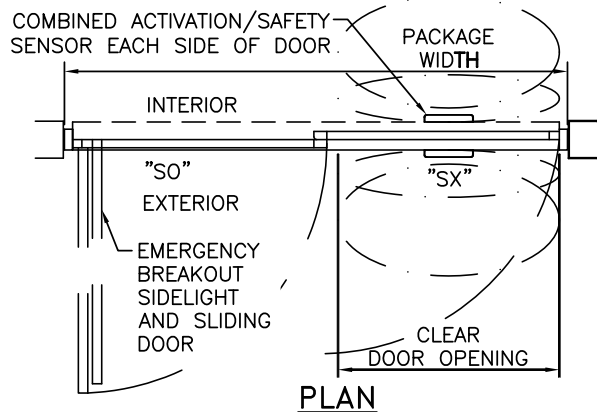
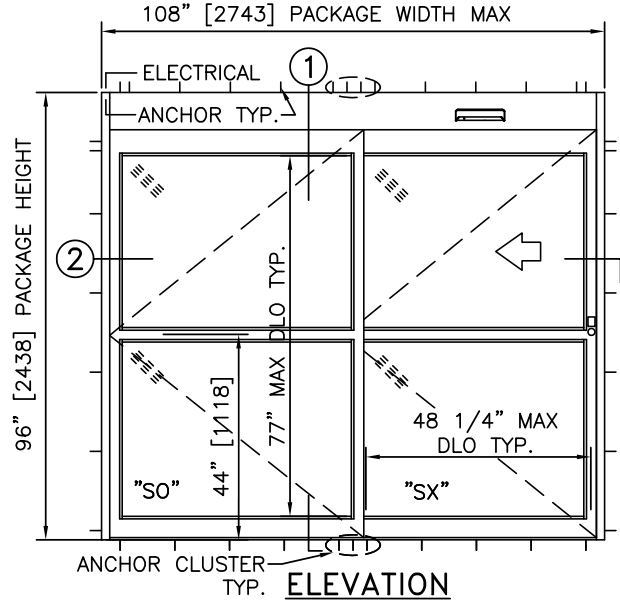

PLAN

NOTES

1. ELECTRICAL REQUIREMENTS: 120 VAC, 5 AMP MIN TO POWER OPERATOR BY ELECTRICAL CONTRACTOR.
2. ROUGH OPENING SHALL PROVIDE 1/4"[6] SHIM SPACE ON SIDES AND TOP OF PACKAGE.
3. ACTIVATION AND SAFETY ZONES ARE FOR REFERENCE ONLY; SEE ANSI/BHMA A156.10 FOR DETAILED REQUIREMENTS.
4. PRODUCT SHALL BE MANUFACTURED AND INSTALLED IN ACCORDANCE WITH PRODUCT APPROVALS; SEE MIAMI-DADE COUNTY NOTICE OF ACCEPTANCE OR FLORIDA BUILDING CODE APPROVAL
5. SEE SPECIFICATIONS FOR ADDITIONAL INFORMATION.

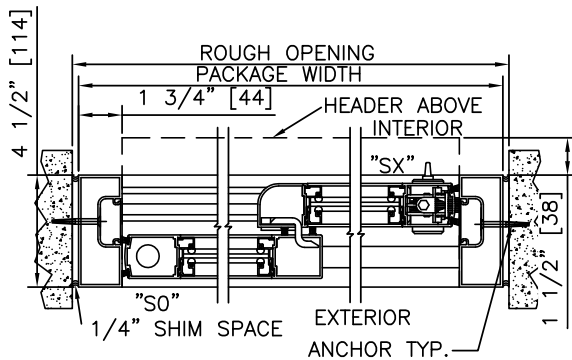

2 HORIZONTAL SECTION

MAX. PACKAGE DIMENSIONS (NARROW STILE)			
PACKAGE WIDTH	NOMINAL CLEAR DOOR OPENING	DOOR PANEL NOMINAL WIDTH	EMERGENCY BREAKOUT NOM. WIDTH
108"	47.3"	53.5"	99.0"

DESIGN RATINGS	
MISSILE IMPACT RATING	
N/A	LARGE AND SMALL MISSILE IMPACT
DESIGN PRESSURE RATING (PSF[Pa])	
POSITIVE	55 PSF [2633 Pa]
NEGATIVE	55 PSF [2633 Pa]

DURA-STORM
3000
NON-IMPACT
SERIES

SINGLE SLIDE RIGHT HAND WITH PANIC RELEASE

PROJECT INFORMATION

PROJECT NAME:

LOCATION:

DOOR NUMBER(S):

DATE:

SHEET: OF

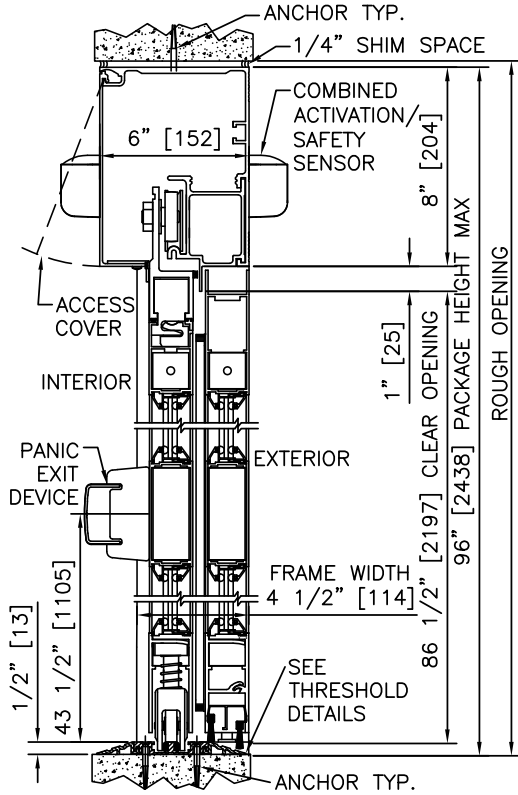

1 VERTICAL SECTION

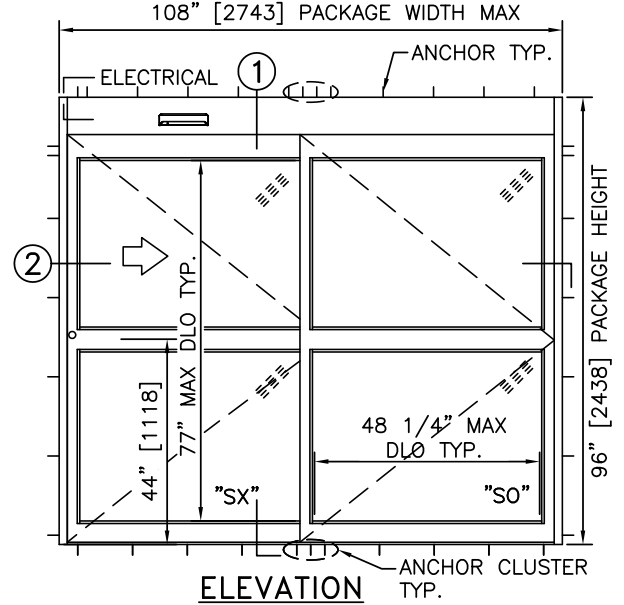

ELEVATION

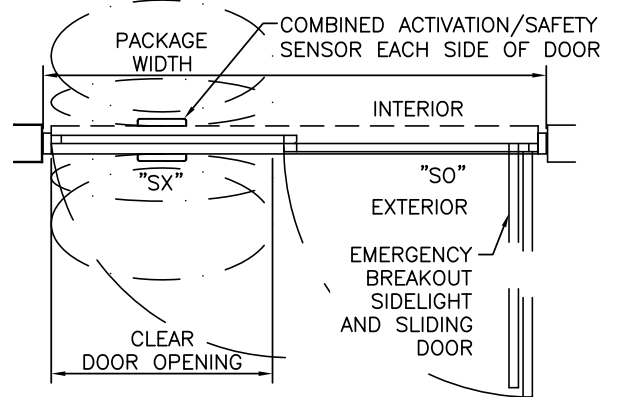

PLAN

NOTES

1. ELECTRICAL REQUIREMENTS: 120 VAC, 5 AMP MIN TO POWER OPERATOR BY ELECTRICAL CONTRACTOR.
2. ROUGH OPENING SHALL PROVIDE 1/4"[6] SHIM SPACE ON SIDES AND TOP OF PACKAGE.
3. ACTIVATION AND SAFETY ZONES ARE FOR REFERENCE ONLY; SEE ANSI/BHMA A156.10 FOR DETAILED REQUIREMENTS.
4. PRODUCT SHALL BE MANUFACTURED AND INSTALLED IN ACCORDANCE WITH PRODUCT APPROVALS; SEE MIAMI-DADE COUNTY NOTICE OF ACCEPTANCE OR FLORIDA BUILDING CODE APPROVAL
5. SEE SPECIFICATIONS FOR ADDITIONAL INFORMATION.

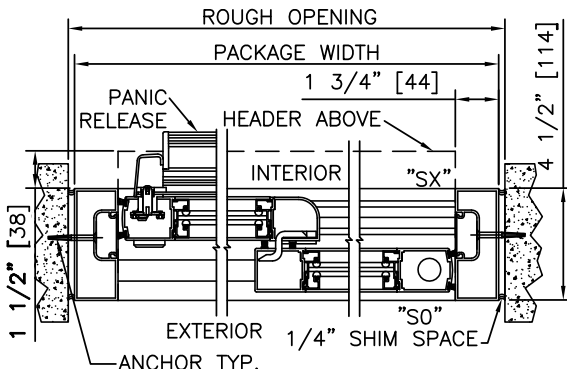

2 HORIZONTAL SECTION

MAX. PACKAGE DIMENSIONS (NARROW STILE)			
PACKAGE WIDTH	NOMINAL CLEAR DOOR OPENING	DOOR PANEL NOMINAL WIDTH	EMERGENCY BREAKOUT NOM. WIDTH
108"	47.3"	53.5"	99.0"

DESIGN RATINGS	
MISSILE IMPACT RATING	
N/A	LARGE AND SMALL MISSILE IMPACT
DESIGN PRESSURE RATING (PSF[Pa])	
POSITIVE	55 PSF [2633 Pa]
NEGATIVE	55 PSF [2633 Pa]

**DURA-STORM
3000
NON-IMPACT
SERIES**

SINGLE SLIDE LEFT HAND WITH PANIC RELEASE

PROJECT INFORMATION

PROJECT NAME:

LOCATION:

DOOR NUMBER(S):

DATE:

SHEET: OF

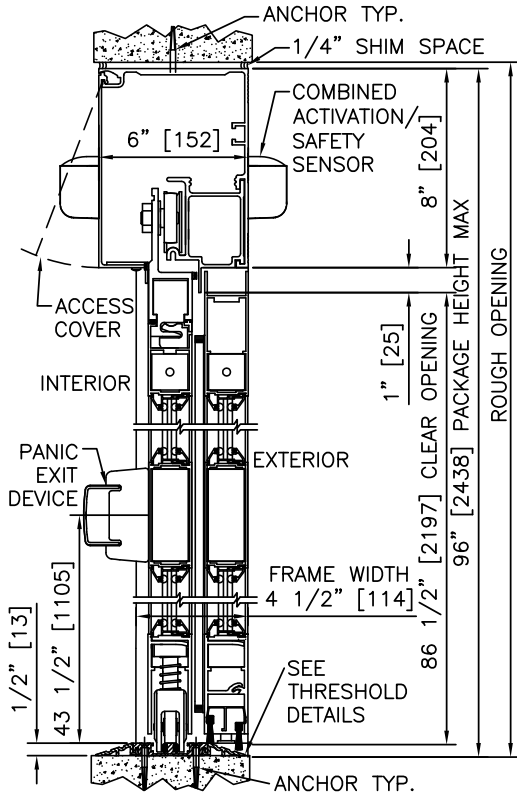

① VERTICAL SECTION

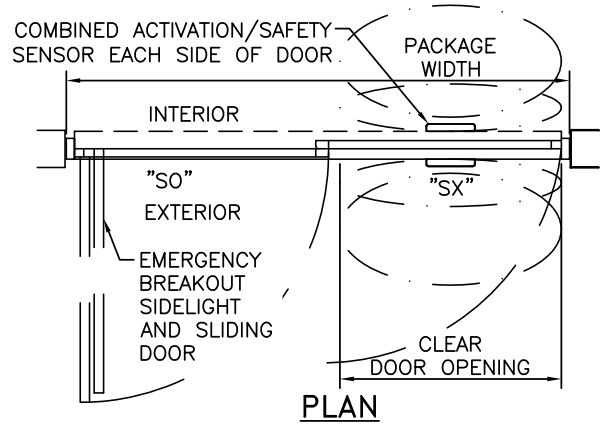
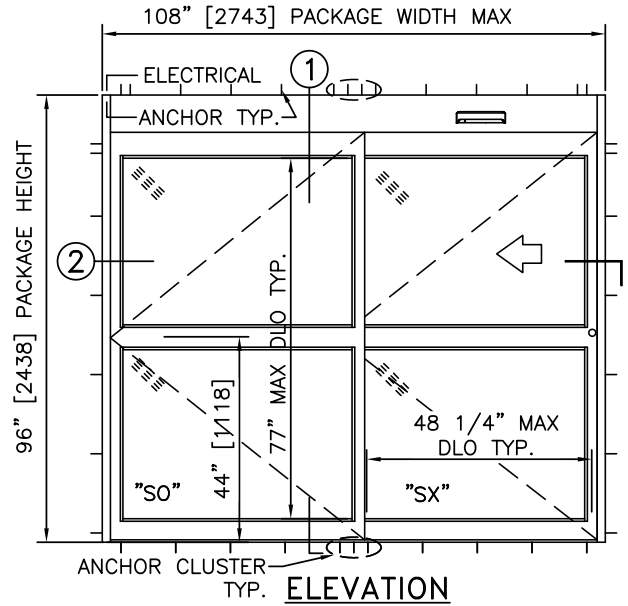

NOTES

1. ELECTRICAL REQUIREMENTS: 120 VAC, 5 AMP MIN TO POWER OPERATOR BY ELECTRICAL CONTRACTOR.
2. ROUGH OPENING SHALL PROVIDE 1/4"[6] SHIM SPACE ON SIDES AND TOP OF PACKAGE.
3. ACTIVATION AND SAFETY ZONES ARE FOR REFERENCE ONLY; SEE ANSI/BHMA A156.10 FOR DETAILED REQUIREMENTS.
4. PRODUCT SHALL BE MANUFACTURED AND INSTALLED IN ACCORDANCE WITH PRODUCT APPROVALS; SEE MIAMI-DADE COUNTY NOTICE OF ACCEPTANCE OR FLORIDA BUILDING CODE APPROVAL
5. SEE SPECIFICATIONS FOR ADDITIONAL INFORMATION.

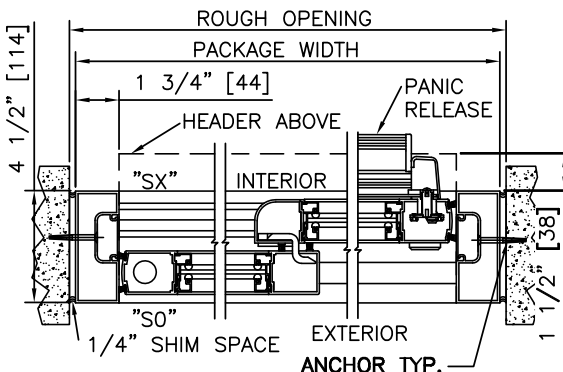

② HORIZONTAL SECTION

MAX. PACKAGE DIMENSIONS (NARROW STILE)			
PACKAGE WIDTH	NOMINAL CLEAR DOOR OPENING	DOOR PANEL NOMINAL WIDTH	EMERGENCY BREAKOUT NOM. WIDTH
108"	47.3"	53.5"	99.0"

DESIGN RATINGS	
MISSILE IMPACT RATING	
N/A	LARGE AND SMALL MISSILE IMPACT
DESIGN PRESSURE RATING (PSF [Pa])	
POSITIVE	55 PSF [2633 Pa]
NEGATIVE	55 PSF [2633 Pa]

**DURA-STORM
3000
NON-IMPACT
SERIES**

SINGLE SLIDE RIGHT HAND WITH TRANSOM

PROJECT INFORMATION

PROJECT NAME:

LOCATION:

DOOR NUMBER(S):

DATE:

SHEET: OF

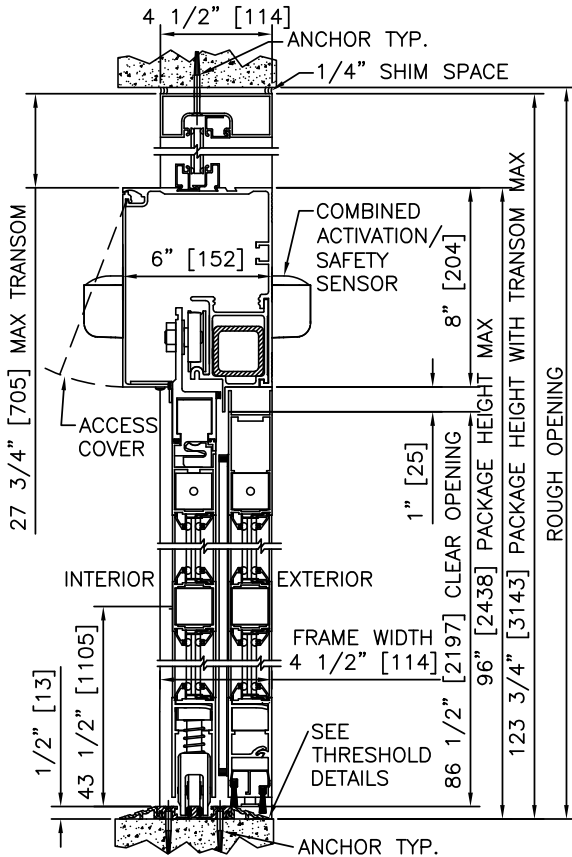

1 VERTICAL SECTION

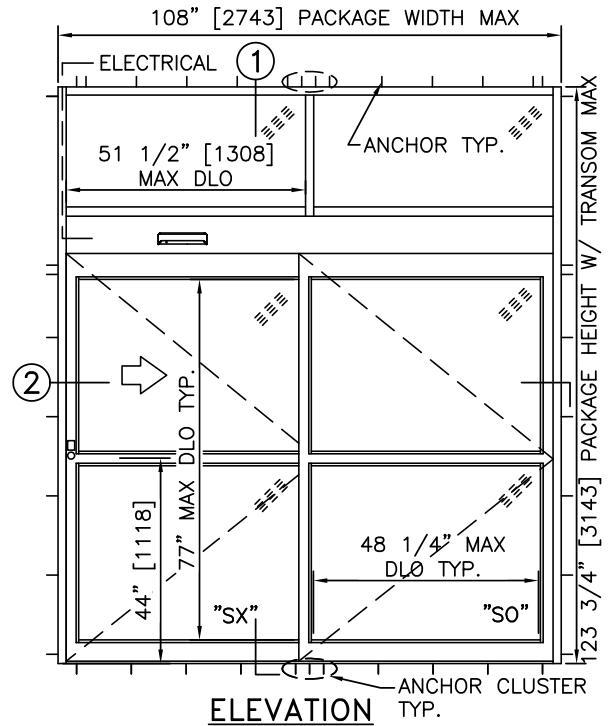

ELEVATION

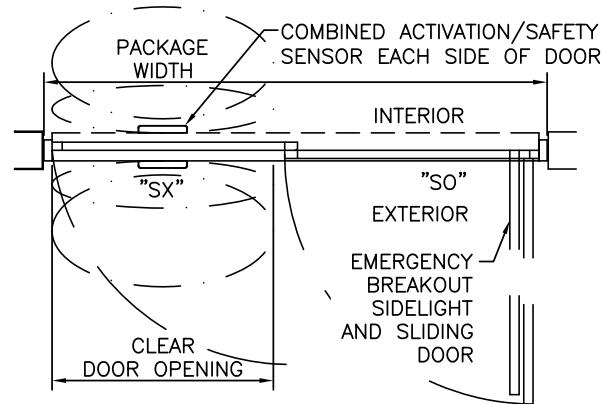

PLAN

NOTES

1. ELECTRICAL REQUIREMENTS: 120 VAC, 5 AMP MIN TO POWER OPERATOR BY ELECTRICAL CONTRACTOR.
2. ROUGH OPENING SHALL PROVIDE 1/4"[6] SHIM SPACE ON SIDES AND TOP OF PACKAGE.
3. ACTIVATION AND SAFETY ZONES ARE FOR REFERENCE ONLY; SEE ANSI/BHMA A156.10 FOR DETAILED REQUIREMENTS.
4. PRODUCT SHALL BE MANUFACTURED AND INSTALLED IN ACCORDANCE WITH PRODUCT APPROVALS; SEE MIAMI-DADE COUNTY NOTICE OF ACCEPTANCE OR FLORIDA BUILDING CODE APPROVAL
5. SEE SPECIFICATIONS FOR ADDITIONAL INFORMATION.

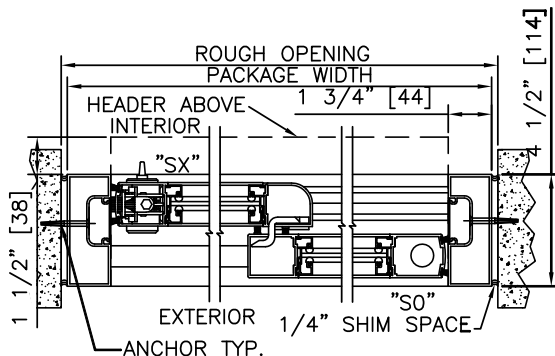

2 HORIZONTAL SECTION

MAX. PACKAGE DIMENSIONS (NARROW STILE)			
PACKAGE WIDTH	NOMINAL CLEAR DOOR OPENING	DOOR PANEL NOMINAL WIDTH	EMERGENCY BREAKOUT NOM. WIDTH
108"	47.3"	53.5"	99.0"

DESIGN RATINGS	
MISSILE IMPACT RATING	
N/A	LARGE AND SMALL MISSILE IMPACT
DESIGN PRESSURE RATING (PSF[Pa])	
POSITIVE	55 PSF [2633 Pa]
NEGATIVE	55 PSF [2633 Pa]

**DURA-STORM
3000
NON-IMPACT
SERIES**

SINGLE SLIDE LEFT HAND WITH TRANSON

PROJECT INFORMATION

PROJECT NAME:

LOCATION:

DOOR NUMBER(S):

DATE:

SHEET: OF

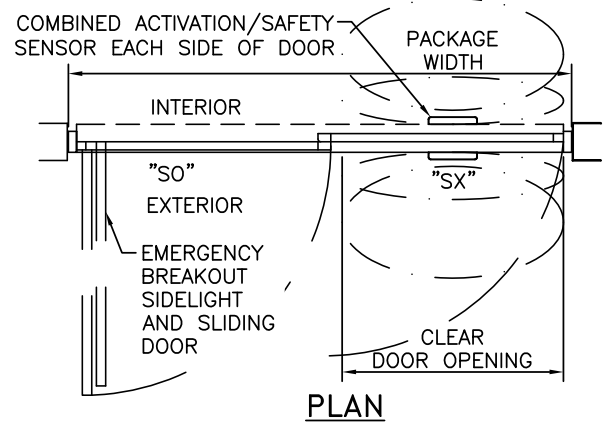
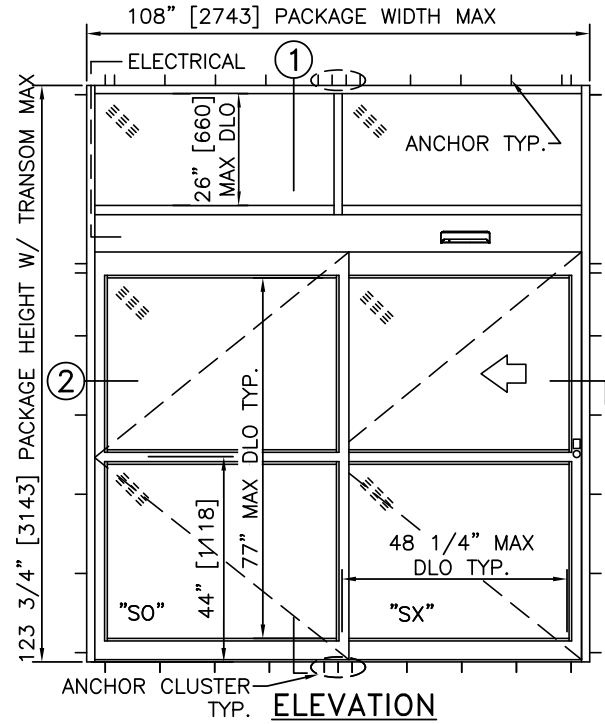
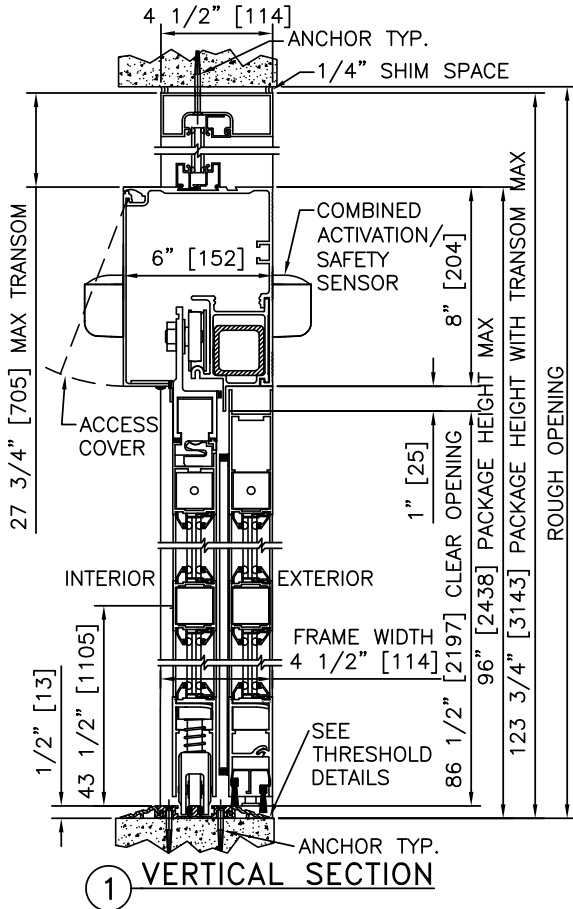

NOTES

1. ELECTRICAL REQUIREMENTS: 120 VAC, 5 AMP MIN TO POWER OPERATOR BY ELECTRICAL CONTRACTOR.
2. ROUGH OPENING SHALL PROVIDE 1/4"[6] SHIM SPACE ON SIDES AND TOP OF PACKAGE.
3. ACTIVATION AND SAFETY ZONES ARE FOR REFERENCE ONLY; SEE ANSI/BHMA A156.10 FOR DETAILED REQUIREMENTS.
4. PRODUCT SHALL BE MANUFACTURED AND INSTALLED IN ACCORDANCE WITH PRODUCT APPROVALS; SEE MIAMI-DADE COUNTY NOTICE OF ACCEPTANCE OR FLORIDA BUILDING CODE APPROVAL
5. SEE SPECIFICATIONS FOR ADDITIONAL INFORMATION.

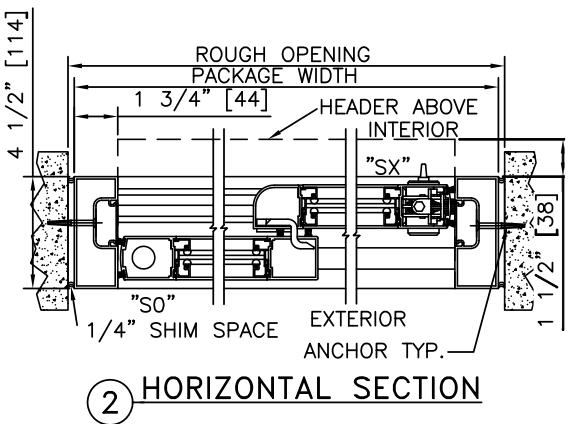

MAX. PACKAGE DIMENSIONS (NARROW STILE)			
PACKAGE WIDTH	NOMINAL CLEAR DOOR OPENING	DOOR PANEL NOMINAL WIDTH	EMERGENCY BREAKOUT NOM. WIDTH
108"	47.3"	53.5"	99.0"

DESIGN RATINGS	
MISSILE IMPACT RATING	
N/A	LARGE AND SMALL MISSILE IMPACT
DESIGN PRESSURE RATING (PSF[Pa])	
POSITIVE	55 PSF [2633 Pa]
NEGATIVE	55 PSF [2633 Pa]

**DURA-STORM
3000
NON-IMPACT
SERIES**

SINGLE SLIDE RIGHT HAND WITH PANIC RELEASE & TRANSOM

PROJECT INFORMATION

PROJECT NAME:

LOCATION:

DOOR NUMBER(S):

DATE:

SHEET: OF

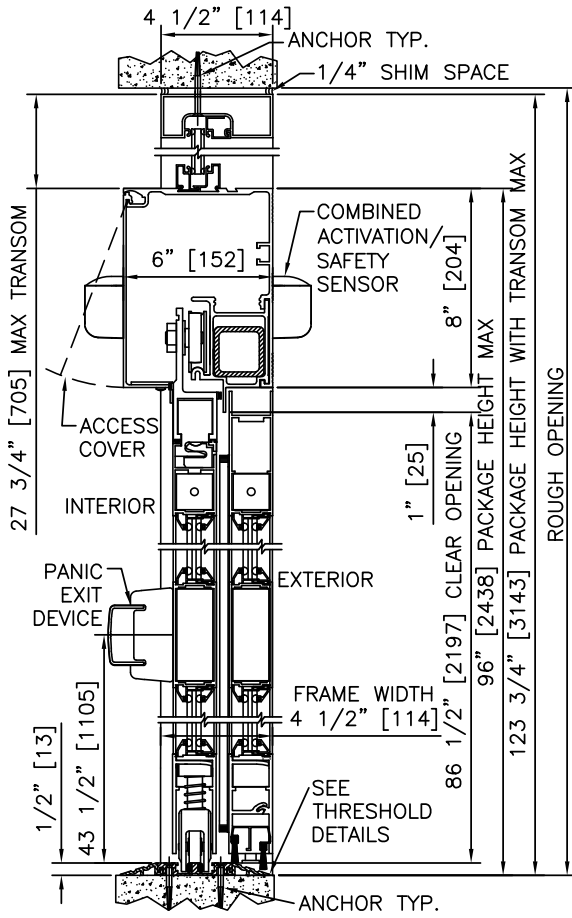

1 VERTICAL SECTION

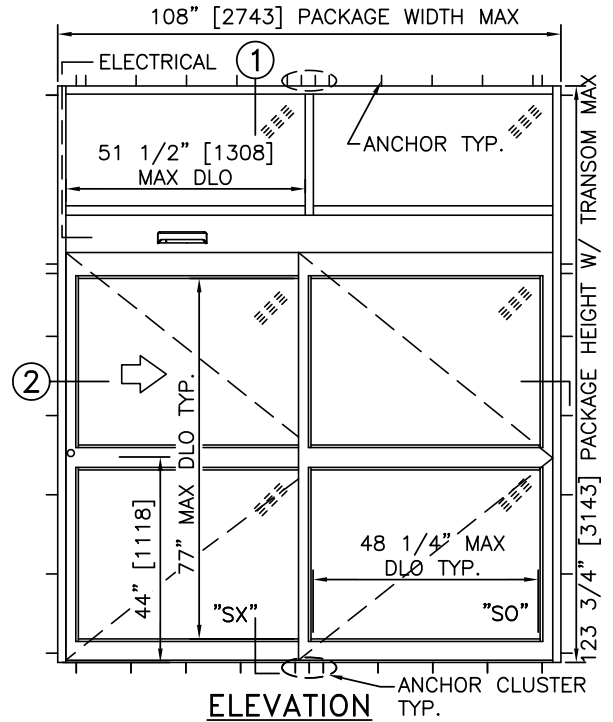

ELEVATION

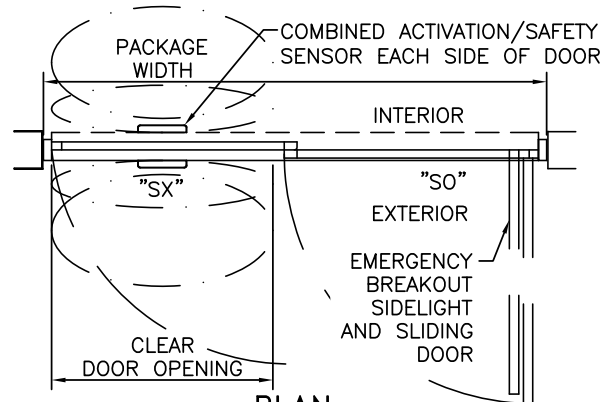

PLAN

NOTES

1. ELECTRICAL REQUIREMENTS: 120 VAC, 5 AMP MIN TO POWER OPERATOR BY ELECTRICAL CONTRACTOR.
2. ROUGH OPENING SHALL PROVIDE 1/4"[6] SHIM SPACE ON SIDES AND TOP OF PACKAGE.
3. ACTIVATION AND SAFETY ZONES ARE FOR REFERENCE ONLY; SEE ANSI/BHMA A156.10 FOR DETAILED REQUIREMENTS.
4. PRODUCT SHALL BE MANUFACTURED AND INSTALLED IN ACCORDANCE WITH PRODUCT APPROVALS; SEE MIAMI-DADE COUNTY NOTICE OF ACCEPTANCE OR FLORIDA BUILDING CODE APPROVAL
5. SEE SPECIFICATIONS FOR ADDITIONAL INFORMATION.

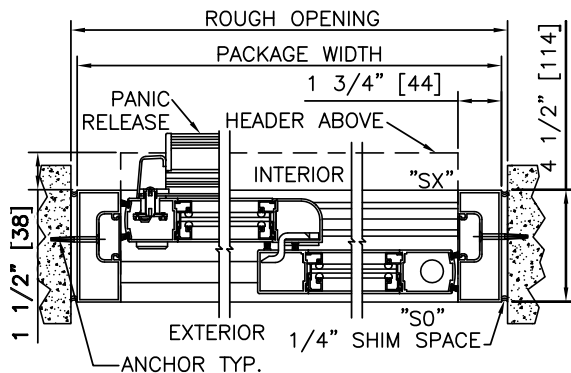

2 HORIZONTAL SECTION

MAX. PACKAGE DIMENSIONS (NARROW STILE)			
PACKAGE WIDTH	NOMINAL CLEAR DOOR OPENING	DOOR PANEL NOMINAL WIDTH	EMERGENCY BREAKOUT NOM. WIDTH
108"	47.3"	53.5"	99.0"

DESIGN RATINGS	
MISSILE IMPACT RATING	
N/A	LARGE AND SMALL MISSILE IMPACT
DESIGN PRESSURE RATING (PSF[Pa])	
POSITIVE	55 PSF [2633 Pa]
NEGATIVE	55 PSF [2633 Pa]

**DURA-STORM
3000
NON-IMPACT
SERIES**

SINGLE SLIDE LEFT HAND WITH PANIC RELEASE & TRANSOM

PROJECT INFORMATION

PROJECT NAME:

LOCATION:

DOOR NUMBER(S):

DATE:

SHEET: OF

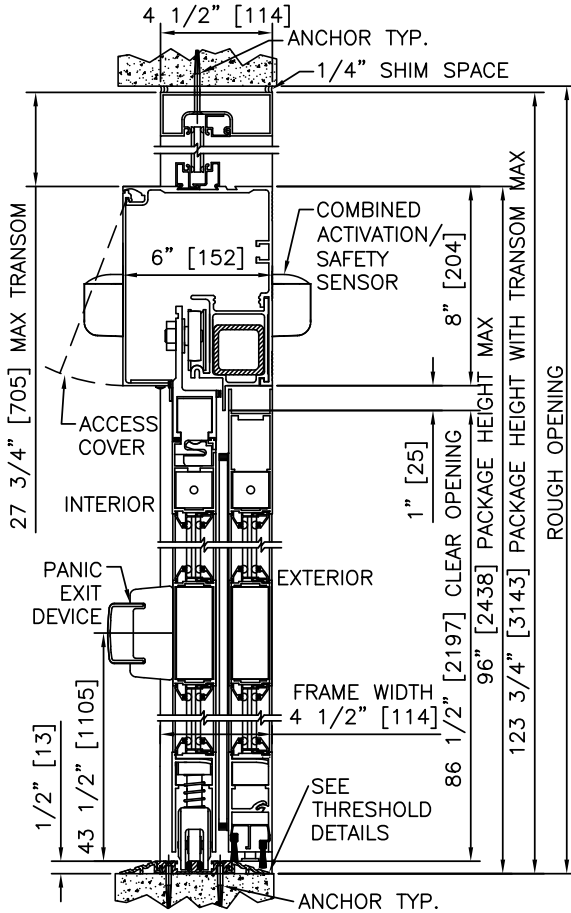

1 VERTICAL SECTION

NOTES

1. ELECTRICAL REQUIREMENTS: 120 VAC, 5 AMP MIN TO POWER OPERATOR BY ELECTRICAL CONTRACTOR.
2. ROUGH OPENING SHALL PROVIDE 1/4"[6] SHIM SPACE ON SIDES AND TOP OF PACKAGE.
3. ACTIVATION AND SAFETY ZONES ARE FOR REFERENCE ONLY; SEE ANSI/BHMA A156.10 FOR DETAILED REQUIREMENTS.
4. PRODUCT SHALL BE MANUFACTURED AND INSTALLED IN ACCORDANCE WITH PRODUCT APPROVALS; SEE MIAMI-DADE COUNTY NOTICE OF ACCEPTANCE OR FLORIDA BUILDING CODE APPROVAL
5. SEE SPECIFICATIONS FOR ADDITIONAL INFORMATION.

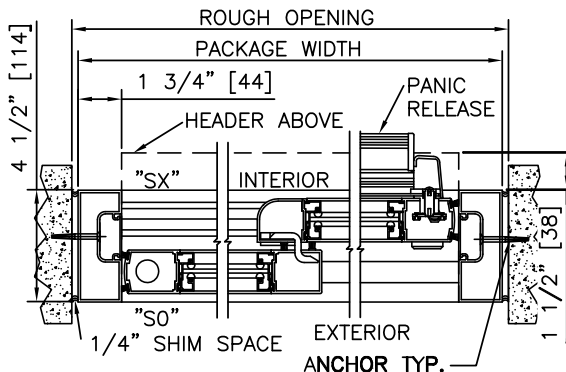
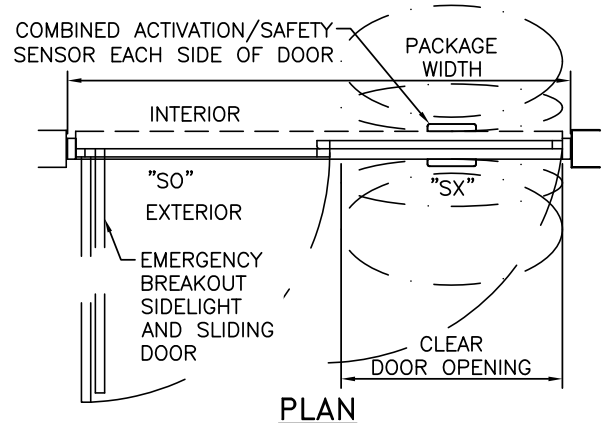
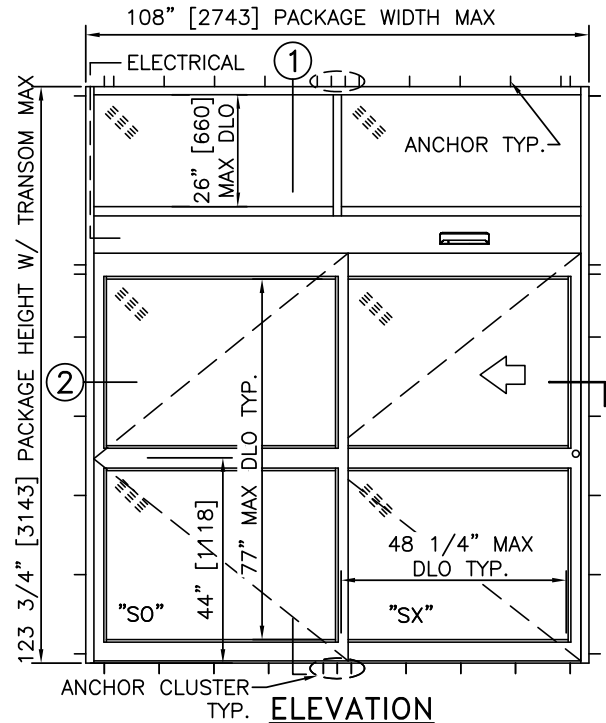

2 HORIZONTAL SECTION

MAX. PACKAGE DIMENSIONS (NARROW STILE)			
PACKAGE WIDTH	NOMINAL CLEAR DOOR OPENING	DOOR PANEL NOMINAL WIDTH	EMERGENCY BREAKOUT NOM. WIDTH
108"	47.3"	53.5"	99.0"

DESIGN RATINGS	
MISSILE IMPACT RATING	
N/A	LARGE AND SMALL MISSILE IMPACT
DESIGN PRESSURE RATING (PSF[Pa])	
POSITIVE	55 PSF [2633 Pa]
NEGATIVE	55 PSF [2633 Pa]

**DURA-STORM
3000
NON-IMPACT
SERIES**

SINGLE SLIDE RIGHT HAND WITH AUTOMATIC LOCKING

PROJECT INFORMATION

PROJECT NAME:

LOCATION:

DOOR NUMBER(S):

DATE:

SHEET: OF

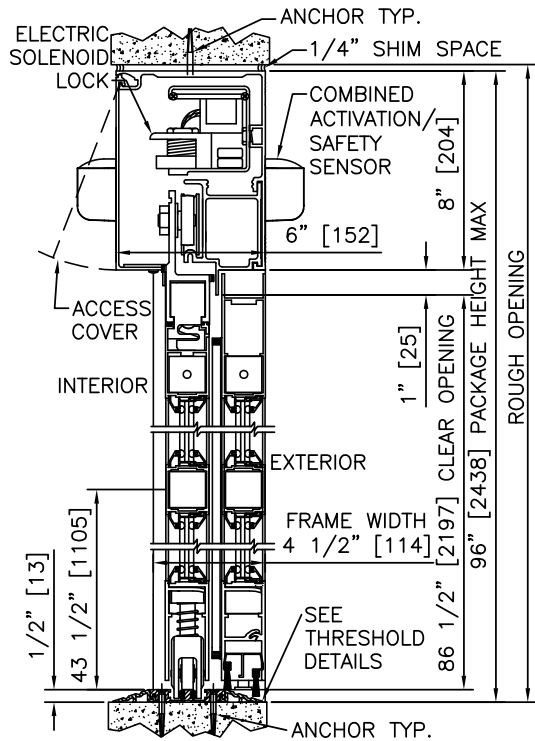

1 VERTICAL SECTION

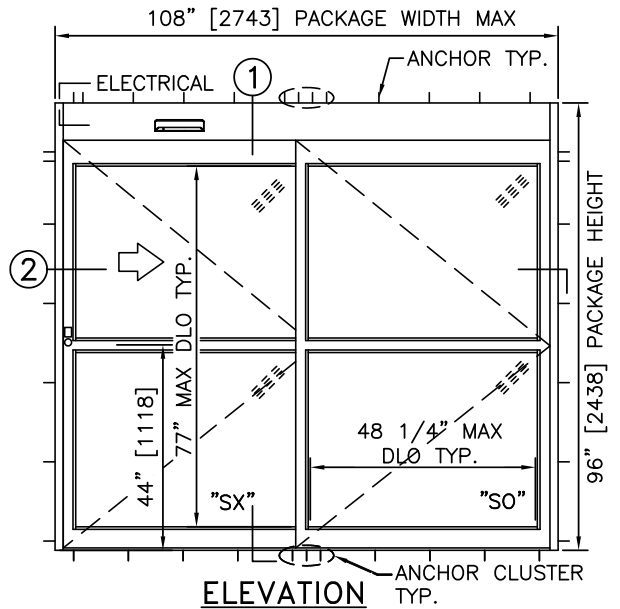

ELEVATION

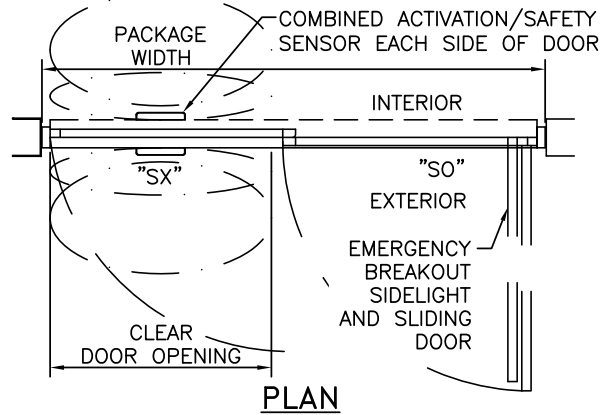

PLAN

NOTES

1. ELECTRICAL REQUIREMENTS: BY ELECTRICAL CONTRACTOR
 - 1.1. 120 VAC, 5 AMP MIN TO POWER OPERATOR.
 - 1.2. CONTROL CIRCUIT FROM SECURE ACTIVATION TO OPERATOR.
2. ROUGH OPENING SHALL PROVIDE 1/4" [6] SHIM SPACE ON SIDES AND TOP OF PACKAGE.
3. ACTIVATION AND SAFETY ZONES ARE FOR REFERENCE ONLY; SEE ANSI/BHMA A156.10 FOR DETAILED REQUIREMENTS.
4. PRODUCT SHALL BE MANUFACTURED AND INSTALLED IN ACCORDANCE WITH PRODUCT APPROVALS; SEE MIAMI-DADE COUNTY NOTICE OF ACCEPTANCE OR FLORIDA BUILDING CODE APPROVAL
5. SEE SPECIFICATIONS FOR ADDITIONAL INFORMATION.

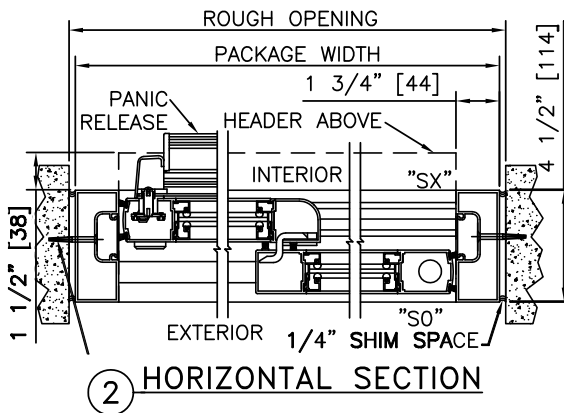

2 HORIZONTAL SECTION

MAX. PACKAGE DIMENSIONS (NARROW STILE)			
PACKAGE WIDTH	NOMINAL CLEAR DOOR OPENING	DOOR PANEL NOMINAL WIDTH	EMERGENCY BREAKOUT NOM. WIDTH
108"	47.3"	53.5"	99.0"

DESIGN RATINGS	
MISSILE IMPACT RATING	
N/A	LARGE AND SMALL MISSILE IMPACT
DESIGN PRESSURE RATING (PSF [Pa])	
POSITIVE	55 PSF [2633 Pa]
NEGATIVE	55 PSF [2633 Pa]

**DURA-STORM
3000
NON-IMPACT
SERIES**

SINGLE SLIDE LEFT HAND WITH AUTOMATIC LOCKING

PROJECT INFORMATION

PROJECT NAME:

LOCATION:

DOOR NUMBER(S):

DATE:

SHEET: OF

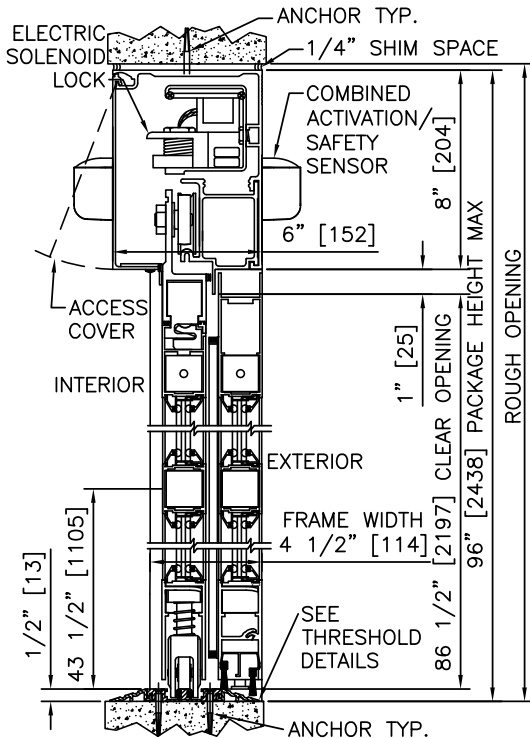

1 VERTICAL SECTION

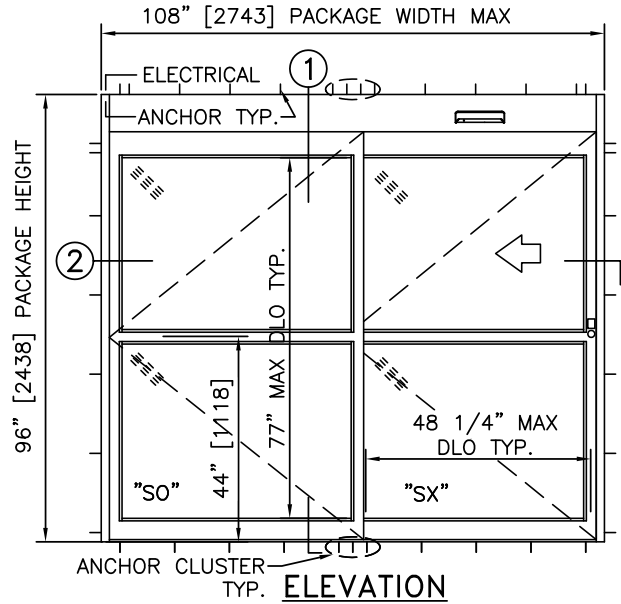

ELEVATION

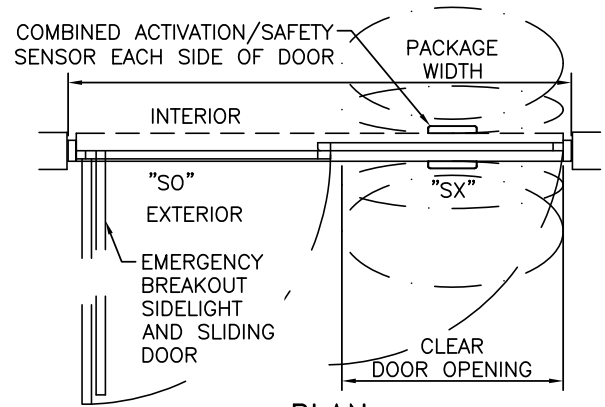

PLAN

NOTES

1. ELECTRICAL REQUIREMENTS: BY ELECTRICAL CONTRACTOR
 - 1.1. 120 VAC, 5 AMP MIN TO POWER OPERATOR.
 - 1.2. CONTROL CIRCUIT FROM SECURE ACTIVATION TO OPERATOR.
2. ROUGH OPENING SHALL PROVIDE 1/4" [6] SHIM SPACE ON SIDES AND TOP OF PACKAGE.
3. ACTIVATION AND SAFETY ZONES ARE FOR REFERENCE ONLY; SEE ANSI/BHMA A156.10 FOR DETAILED REQUIREMENTS.
4. PRODUCT SHALL BE MANUFACTURED AND INSTALLED IN ACCORDANCE WITH PRODUCT APPROVALS; SEE MIAMI-DADE COUNTY NOTICE OF ACCEPTANCE OR FLORIDA BUILDING CODE APPROVAL
5. SEE SPECIFICATIONS FOR ADDITIONAL INFORMATION.

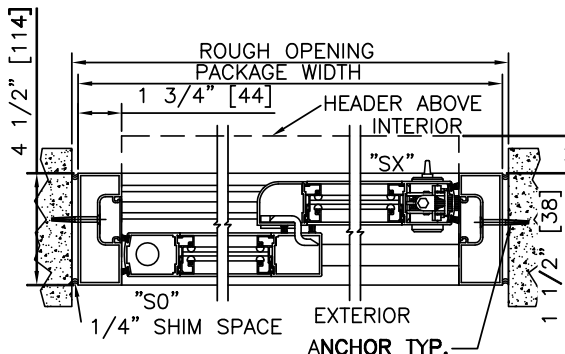

2 HORIZONTAL SECTION

MAX. PACKAGE DIMENSIONS (NARROW STILE)			
PACKAGE WIDTH	NOMINAL CLEAR DOOR OPENING	DOOR PANEL NOMINAL WIDTH	EMERGENCY BREAKOUT NOM. WIDTH
108"	47.3"	53.5"	99.0"

DESIGN RATINGS	
MISSILE IMPACT RATING	
N/A	LARGE AND SMALL MISSILE IMPACT
DESIGN PRESSURE RATING (PSF [Pa])	
POSITIVE	55 PSF [2633 Pa]
NEGATIVE	55 PSF [2633 Pa]

**DURA-STORM
3000
NON-IMPACT
SERIES**

SINGLE SLIDE RIGHT HAND WITH PANIC RELEASE & AUTOMATIC LOCKING

PROJECT INFORMATION

PROJECT NAME:

LOCATION:

DOOR NUMBER(S):

DATE:

SHEET: OF

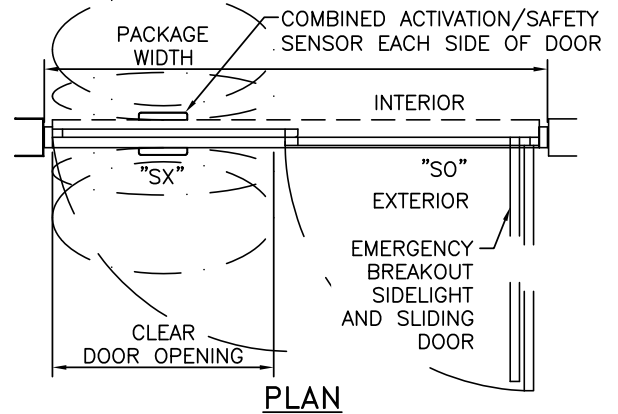
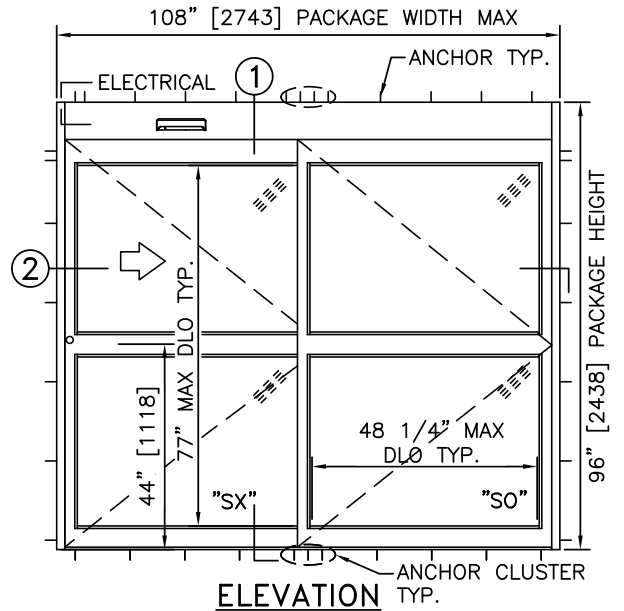
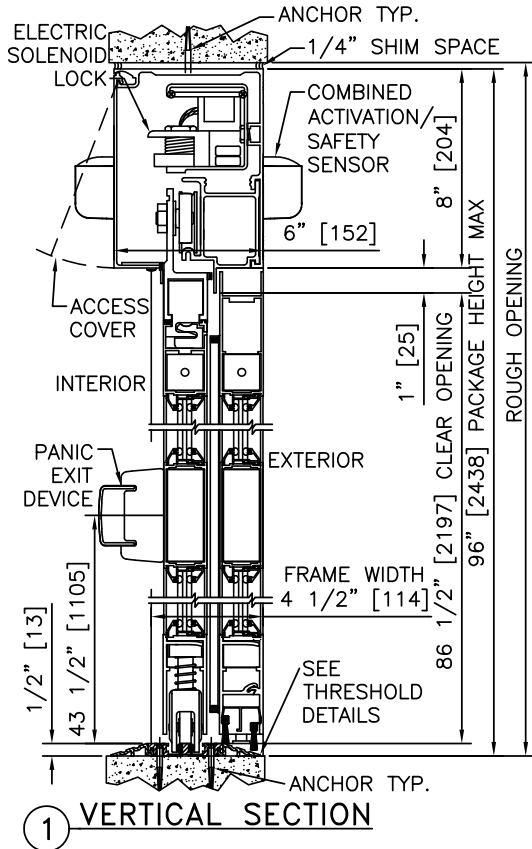

NOTES

1. ELECTRICAL REQUIREMENTS: BY ELECTRICAL CONTRACTOR
 - 1.1. 120 VAC, 5 AMP MIN TO POWER OPERATOR.
 - 1.2. CONTROL CIRCUIT FROM SECURE ACTIVATION TO OPERATOR.
2. ROUGH OPENING SHALL PROVIDE 1/4" [6] SHIM SPACE ON SIDES AND TOP OF PACKAGE.
3. ACTIVATION AND SAFETY ZONES ARE FOR REFERENCE ONLY; SEE ANSI/BHMA A156.10 FOR DETAILED REQUIREMENTS.
4. PRODUCT SHALL BE MANUFACTURED AND INSTALLED IN ACCORDANCE WITH PRODUCT APPROVALS; SEE MIAMI-DADE COUNTY NOTICE OF ACCEPTANCE OR FLORIDA BUILDING CODE APPROVAL
5. SEE SPECIFICATIONS FOR ADDITIONAL INFORMATION.

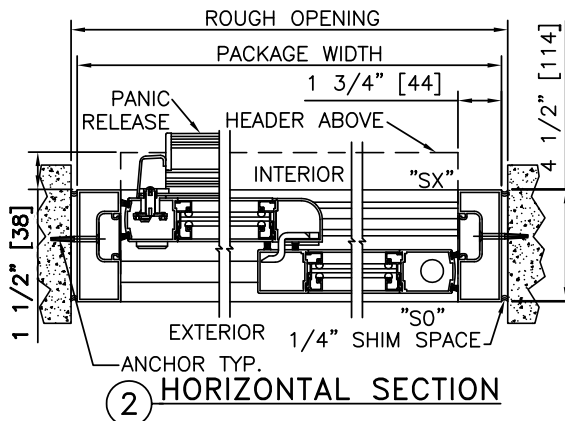

MAX. PACKAGE DIMENSIONS (NARROW STILE)			
PACKAGE WIDTH	NOMINAL CLEAR DOOR OPENING	DOOR PANEL NOMINAL WIDTH	EMERGENCY BREAKOUT NOM. WIDTH
108"	47.3"	53.5"	99.0"

DESIGN RATINGS	
MISSILE IMPACT RATING	
N/A	LARGE AND SMALL MISSILE IMPACT
DESIGN PRESSURE RATING (PSF [Pa])	
POSITIVE	55 PSF [2633 Pa]
NEGATIVE	55 PSF [2633 Pa]

DURA-STORM
3000
NON-IMPACT
SERIES

SINGLE SLIDE LEFT HAND WITH PANIC RELEASE & AUTOMATIC LOCKING

PROJECT INFORMATION

PROJECT NAME:

LOCATION:

DOOR NUMBER(S):

DATE:

SHEET: OF

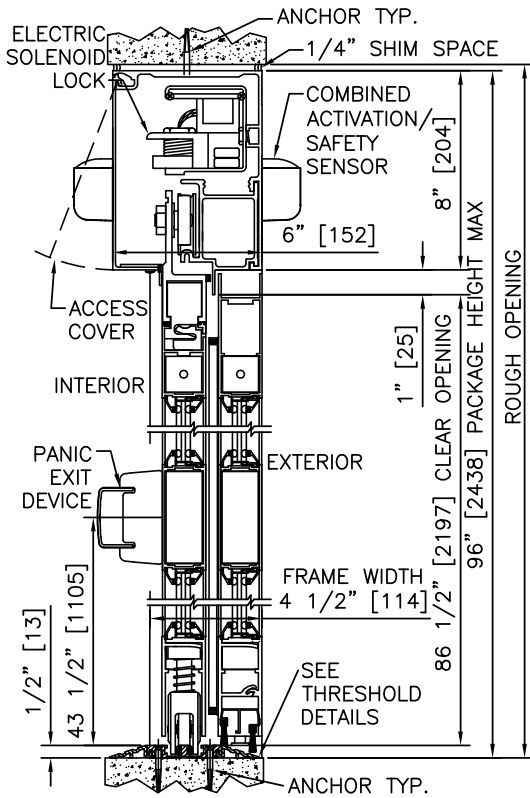

1 VERTICAL SECTION

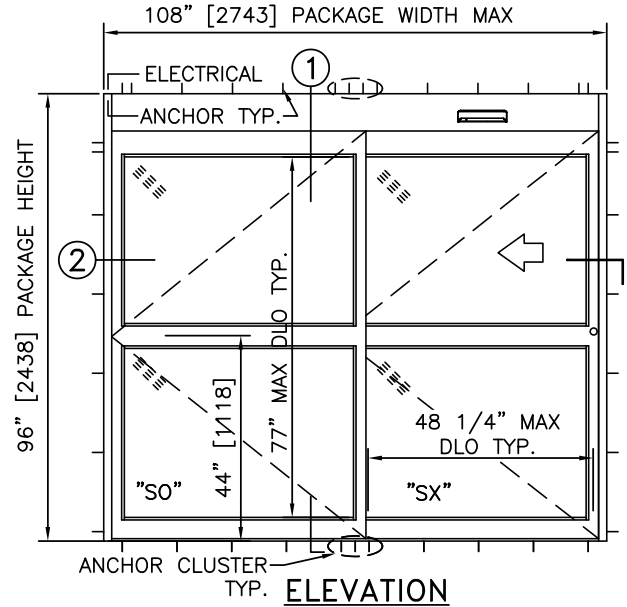

ELEVATION

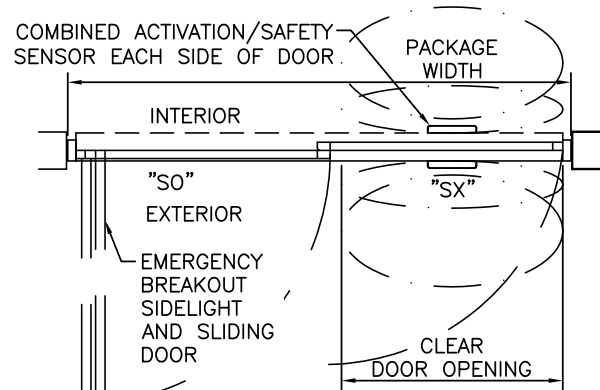

PLAN

NOTES

1. ELECTRICAL REQUIREMENTS: BY ELECTRICAL CONTRACTOR
 - 1.1. 120 VAC, 5 AMP MIN TO POWER OPERATOR.
 - 1.2. CONTROL CIRCUIT FROM SECURE ACTIVATION TO OPERATOR.
2. ROUGH OPENING SHALL PROVIDE 1/4" [6] SHIM SPACE ON SIDES AND TOP OF PACKAGE.
3. ACTIVATION AND SAFETY ZONES ARE FOR REFERENCE ONLY; SEE ANSI/BHMA A156.10 FOR DETAILED REQUIREMENTS.
4. PRODUCT SHALL BE MANUFACTURED AND INSTALLED IN ACCORDANCE WITH PRODUCT APPROVALS; SEE MIAMI-DADE COUNTY NOTICE OF ACCEPTANCE OR FLORIDA BUILDING CODE APPROVAL
5. SEE SPECIFICATIONS FOR ADDITIONAL INFORMATION.

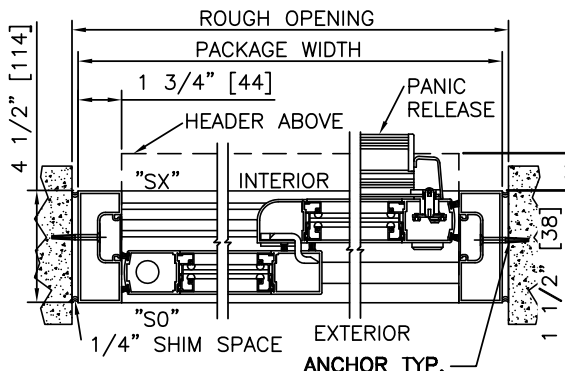

2 HORIZONTAL SECTION

MAX. PACKAGE DIMENSIONS (NARROW STILE)			
PACKAGE WIDTH	NOMINAL CLEAR DOOR OPENING	DOOR PANEL NOMINAL WIDTH	EMERGENCY BREAKOUT NOM. WIDTH
108"	47.3"	53.5"	99.0"

DESIGN RATINGS	
MISSILE IMPACT RATING	
N/A	LARGE AND SMALL MISSILE IMPACT
DESIGN PRESSURE RATING (PSF [Pa])	
POSITIVE	55 PSF [2633 Pa]
NEGATIVE	55 PSF [2633 Pa]

**DURA-STORM
3000
NON-IMPACT
SERIES**

SINGLE SLIDE RIGHT HAND WITH TRANSOM & AUTOMATIC LOCKING

PROJECT INFORMATION

PROJECT NAME:

LOCATION:

DOOR NUMBER(S):

DATE:

SHEET: OF

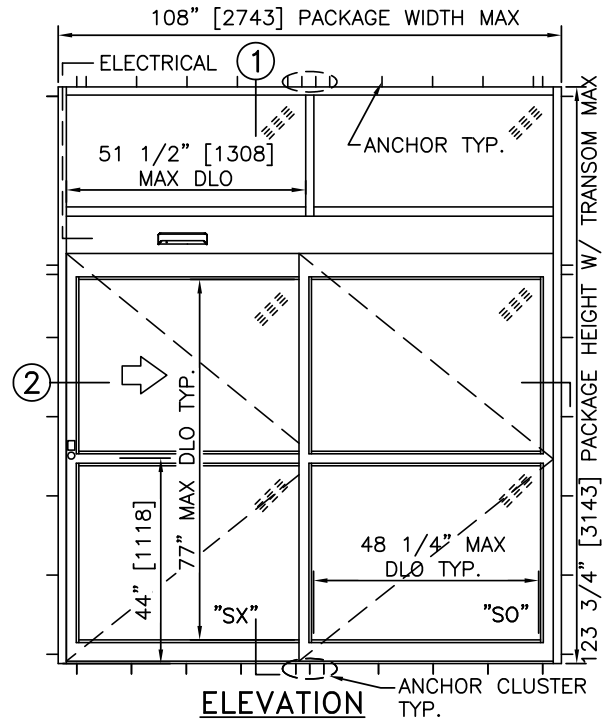
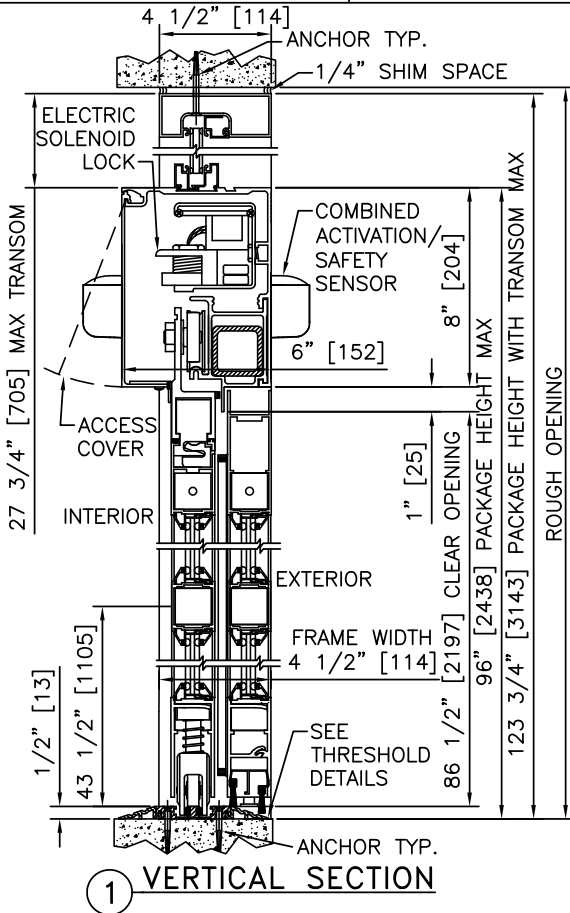

NOTES

1. ELECTRICAL REQUIREMENTS: BY ELECTRICAL CONTRACTOR
 - 1.1. 120 VAC, 5 AMP MIN TO POWER OPERATOR.
 - 1.2. CONTROL CIRCUIT FROM SECURE ACTIVATION TO OPERATOR.
2. ROUGH OPENING SHALL PROVIDE 1/4" [6] SHIM SPACE ON SIDES AND TOP OF PACKAGE.
3. ACTIVATION AND SAFETY ZONES ARE FOR REFERENCE ONLY; SEE ANSI/BHMA A156.10 FOR DETAILED REQUIREMENTS.
4. PRODUCT SHALL BE MANUFACTURED AND INSTALLED IN ACCORDANCE WITH PRODUCT APPROVALS; SEE MIAMI-DADE COUNTY NOTICE OF ACCEPTANCE OR FLORIDA BUILDING CODE APPROVAL
5. SEE SPECIFICATIONS FOR ADDITIONAL INFORMATION.

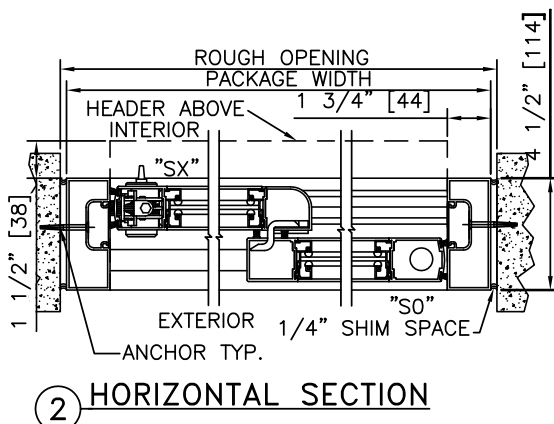
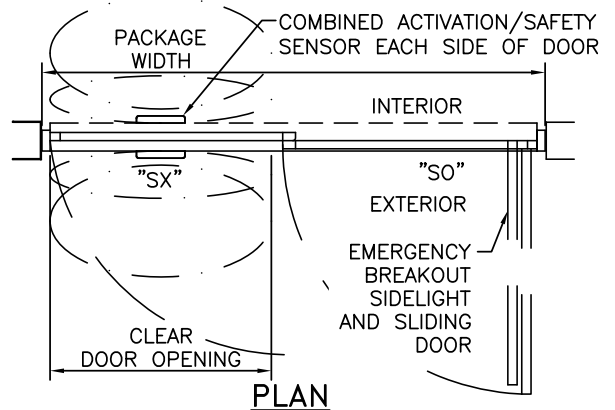

MAX. PACKAGE DIMENSIONS (NARROW STILE)			
PACKAGE WIDTH	NOMINAL CLEAR DOOR OPENING	DOOR PANEL NOMINAL WIDTH	EMERGENCY BREAKOUT NOM. WIDTH
108"	47.3"	53.5"	99.0"

DESIGN RATINGS	
MISSILE IMPACT RATING	
N/A	LARGE AND SMALL MISSILE IMPACT
DESIGN PRESSURE RATING (PSF[Pa])	
POSITIVE	55 PSF [2633 Pa]
NEGATIVE	55 PSF [2633 Pa]

**DURA-STORM
3000
NON-IMPACT
SERIES**

SINGLE SLIDE LEFT HAND WITH TRANSOM & AUTOMATIC LOCKING

PROJECT INFORMATION

PROJECT NAME:

LOCATION:

DOOR NUMBER(S):

DATE:

SHEET: OF

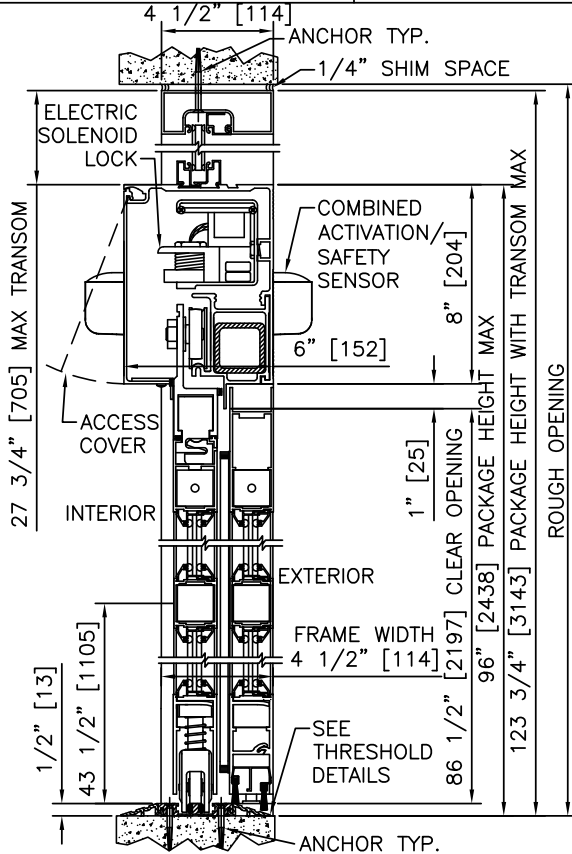

1 VERTICAL SECTION

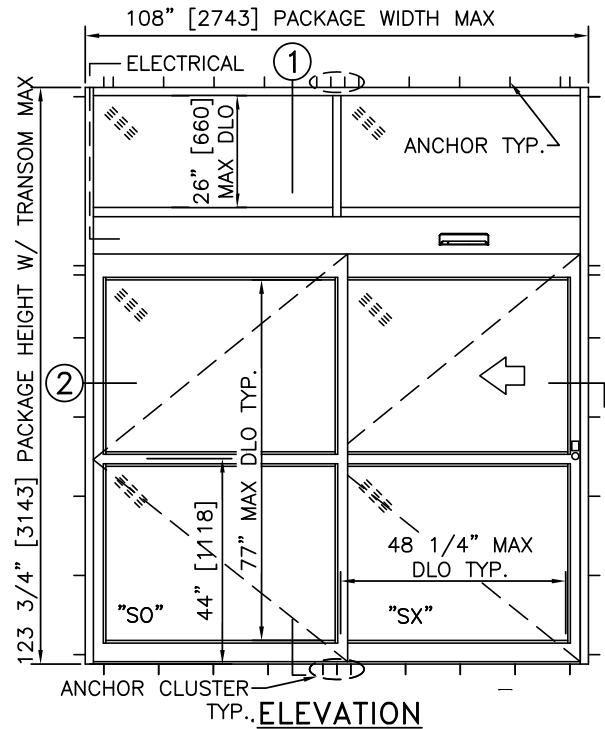

ELEVATION

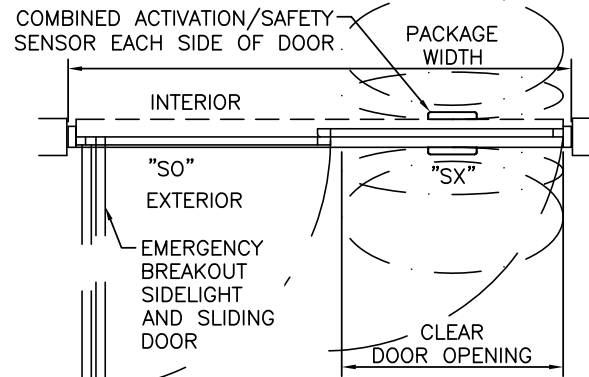

PLAN

NOTES

1. ELECTRICAL REQUIREMENTS: BY ELECTRICAL CONTRACTOR
 - 1.1. 120 VAC, 5 AMP MIN TO POWER OPERATOR.
 - 1.2. CONTROL CIRCUIT FROM SECURE ACTIVATION TO OPERATOR.
2. ROUGH OPENING SHALL PROVIDE 1/4\"[6] SHIM SPACE ON SIDES AND TOP OF PACKAGE.
3. ACTIVATION AND SAFETY ZONES ARE FOR REFERENCE ONLY; SEE ANSI/BHMA A156.10 FOR DETAILED REQUIREMENTS.
4. PRODUCT SHALL BE MANUFACTURED AND INSTALLED IN ACCORDANCE WITH PRODUCT APPROVALS; SEE MIAMI-DADE COUNTY NOTICE OF ACCEPTANCE OR FLORIDA BUILDING CODE APPROVAL
5. SEE SPECIFICATIONS FOR ADDITIONAL INFORMATION.

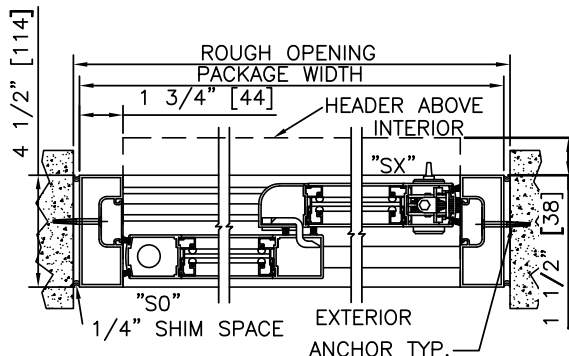

2 HORIZONTAL SECTION

MAX. PACKAGE DIMENSIONS (NARROW STILE)			
PACKAGE WIDTH	NOMINAL CLEAR DOOR OPENING	DOOR PANEL NOMINAL WIDTH	EMERGENCY BREAKOUT NOM. WIDTH
108"	47.3"	53.5"	99.0"

DESIGN RATINGS	
MISSILE IMPACT RATING	
N/A	LARGE AND SMALL MISSILE IMPACT
DESIGN PRESSURE RATING (PSF[Pa])	
POSITIVE	55 PSF [2633 Pa]
NEGATIVE	55 PSF [2633 Pa]

DURA-STORM
3000
NON-IMPACT
SERIES

SINGLE SLIDE RIGHT HAND WITH PANIC RELEASE, TRANSOM & AUTOMATIC LOCKING

PROJECT INFORMATION

PROJECT NAME:

LOCATION:

DOOR NUMBER(S):

DATE:

SHEET: OF

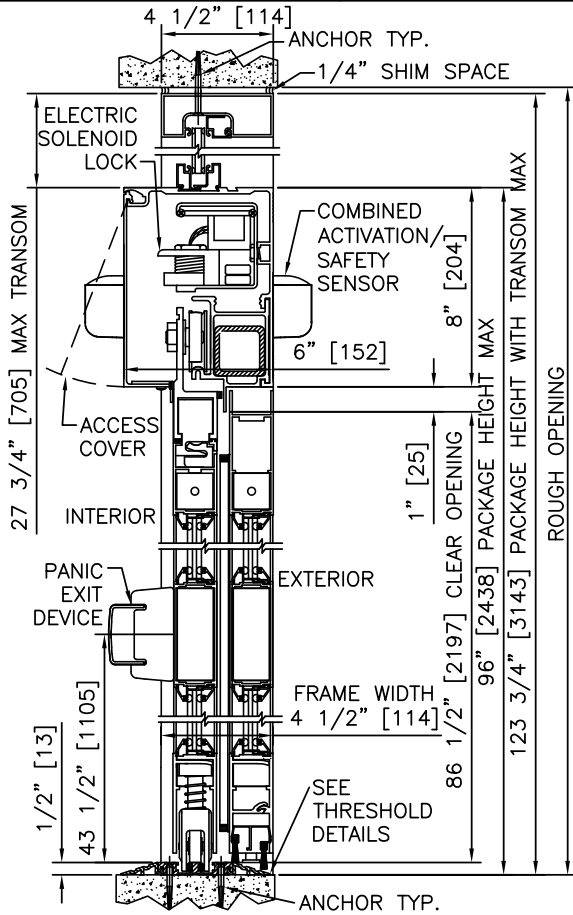

1 VERTICAL SECTION

NOTES

1. ELECTRICAL REQUIREMENTS: BY ELECTRICAL CONTRACTOR
 - 1.1. 120 VAC, 5 AMP MIN TO POWER OPERATOR.
 - 1.2. CONTROL CIRCUIT FROM SECURE ACTIVATION TO OPERATOR.
2. ROUGH OPENING SHALL PROVIDE 1/4" [6] SHIM SPACE ON SIDES AND TOP OF PACKAGE.
3. ACTIVATION AND SAFETY ZONES ARE FOR REFERENCE ONLY; SEE ANSI/BHMA A156.10 FOR DETAILED REQUIREMENTS.
4. PRODUCT SHALL BE MANUFACTURED AND INSTALLED IN ACCORDANCE WITH PRODUCT APPROVALS; SEE MIAMI-DADE COUNTY NOTICE OF ACCEPTANCE OR FLORIDA BUILDING CODE APPROVAL
5. SEE SPECIFICATIONS FOR ADDITIONAL INFORMATION.

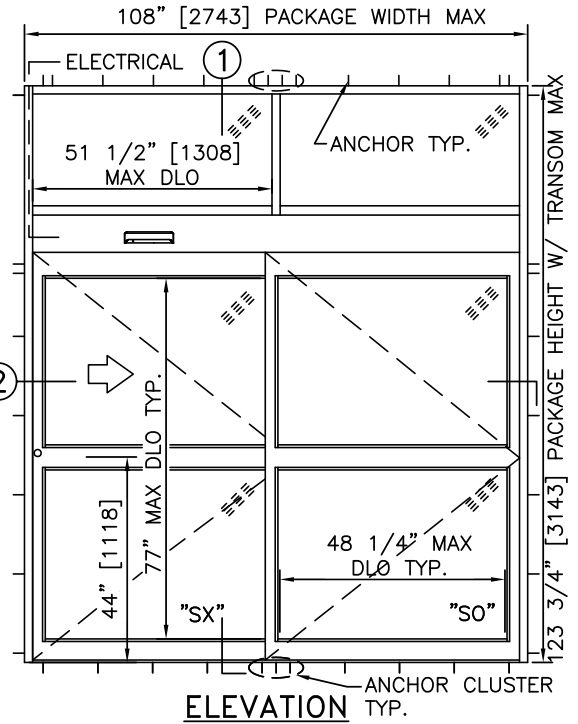

ELEVATION

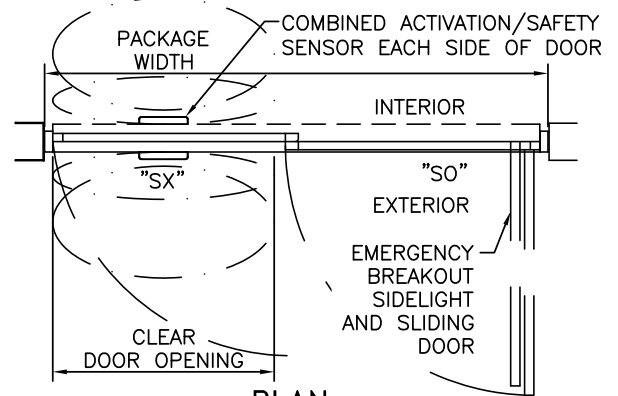

PLAN

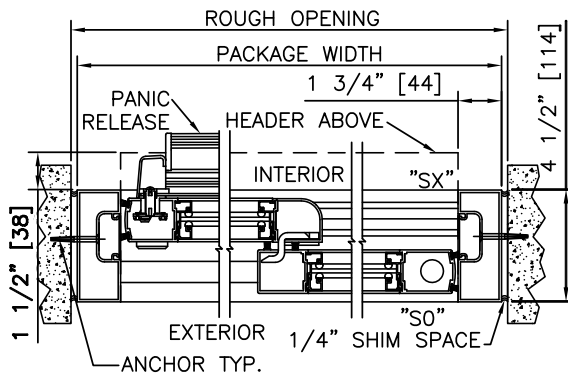

2 HORIZONTAL SECTION

MAX. PACKAGE DIMENSIONS (NARROW STILE)			
PACKAGE WIDTH	NOMINAL CLEAR DOOR OPENING	DOOR PANEL NOMINAL WIDTH	EMERGENCY BREAKOUT NOM. WIDTH
108"	47.3"	53.5"	99.0"

DESIGN RATINGS	
MISSILE IMPACT RATING	
N/A	LARGE AND SMALL MISSILE IMPACT
DESIGN PRESSURE RATING (PSF [Pa])	
POSITIVE	55 PSF [2633 Pa]
NEGATIVE	55 PSF [2633 Pa]

DURA-STORM
3000
NON-IMPACT
SERIES

SINGLE SLIDE LEFT HAND WITH PANIC RELEASE, TRANSOM & AUTOMATIC LOCKING

PROJECT INFORMATION

PROJECT NAME:

LOCATION:

DOOR NUMBER(S):

DATE:

SHEET: OF

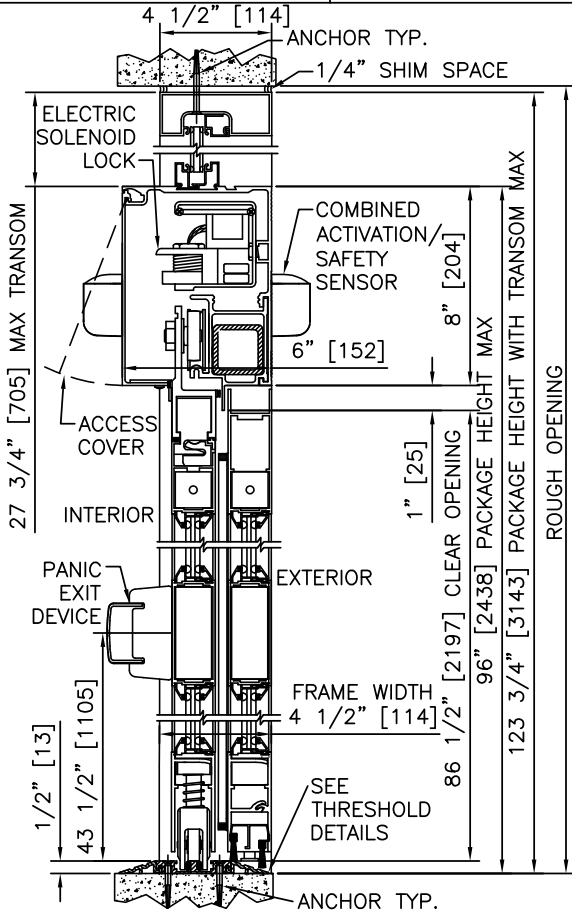

1 VERTICAL SECTION

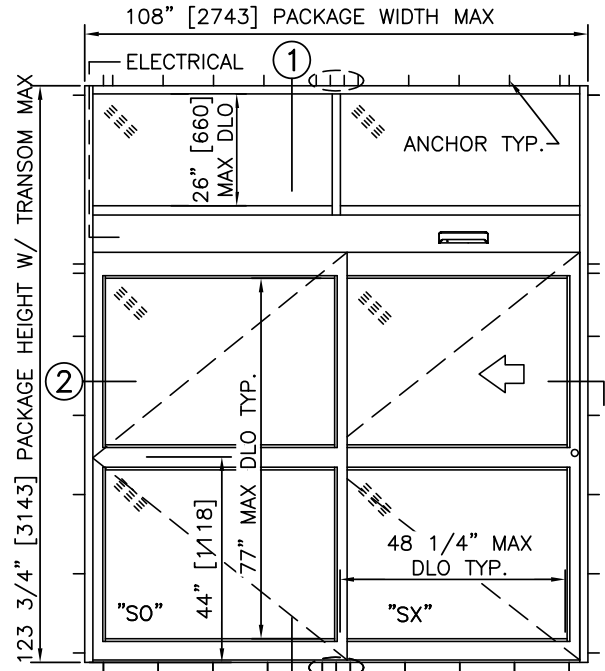

ELEVATION

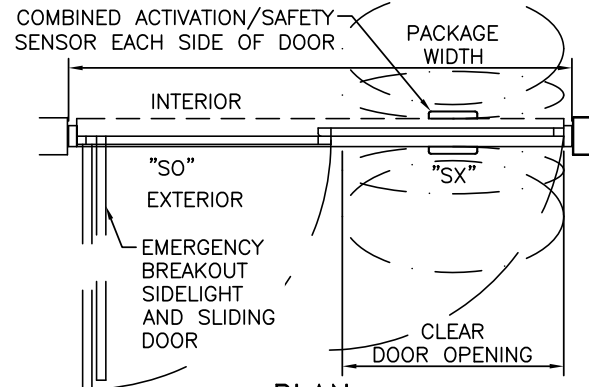

PLAN

NOTES

1. ELECTRICAL REQUIREMENTS: BY ELECTRICAL CONTRACTOR
 - 1.1. 120 VAC, 5 AMP MIN TO POWER OPERATOR.
 - 1.2. CONTROL CIRCUIT FROM SECURE ACTIVATION TO OPERATOR.
2. ROUGH OPENING SHALL PROVIDE 1/4" [6] SHIM SPACE ON SIDES AND TOP OF PACKAGE.
3. ACTIVATION AND SAFETY ZONES ARE FOR REFERENCE ONLY; SEE ANSI/BHMA A156.10 FOR DETAILED REQUIREMENTS.
4. PRODUCT SHALL BE MANUFACTURED AND INSTALLED IN ACCORDANCE WITH PRODUCT APPROVALS; SEE MIAMI-DADE COUNTY NOTICE OF ACCEPTANCE OR FLORIDA BUILDING CODE APPROVAL
5. SEE SPECIFICATIONS FOR ADDITIONAL INFORMATION.

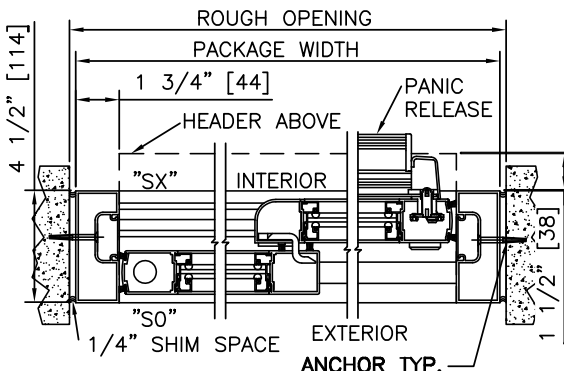

2 HORIZONTAL SECTION

MAX. PACKAGE DIMENSIONS (NARROW STILE)			
PACKAGE WIDTH	NOMINAL CLEAR DOOR OPENING	DOOR PANEL NOMINAL WIDTH	EMERGENCY BREAKOUT NOM. WIDTH
108"	47.3"	53.5"	99.0"

DESIGN RATINGS	
MISSILE IMPACT RATING	
N/A	LARGE AND SMALL MISSILE IMPACT
DESIGN PRESSURE RATING (PSF [Pa])	
POSITIVE	55 PSF [2633 Pa]
NEGATIVE	55 PSF [2633 Pa]