



SLIDING MANUAL ENTRANCES: DURA-CARE™ 7600 SERIES, SPLIT FOLD

3.15 - SPLIT FOLD TRACKLESS

- 3.15.01 - RH, FOLD-IN
- 3.15.02 - LH, FOLD-IN
- 3.15.03 - RH, FOLD-OUT
- 3.15.04 - LH, FOLD-OUT

STANLEY
Access Technologies

DURA-CARE™
7600
SERIES

SPLIT FOLD TRACKLESS

PROJECT INFORMATION

PROJECT NAME:

LOCATION:

DOOR NUMBER(S):

DATE:

SHEET: OF

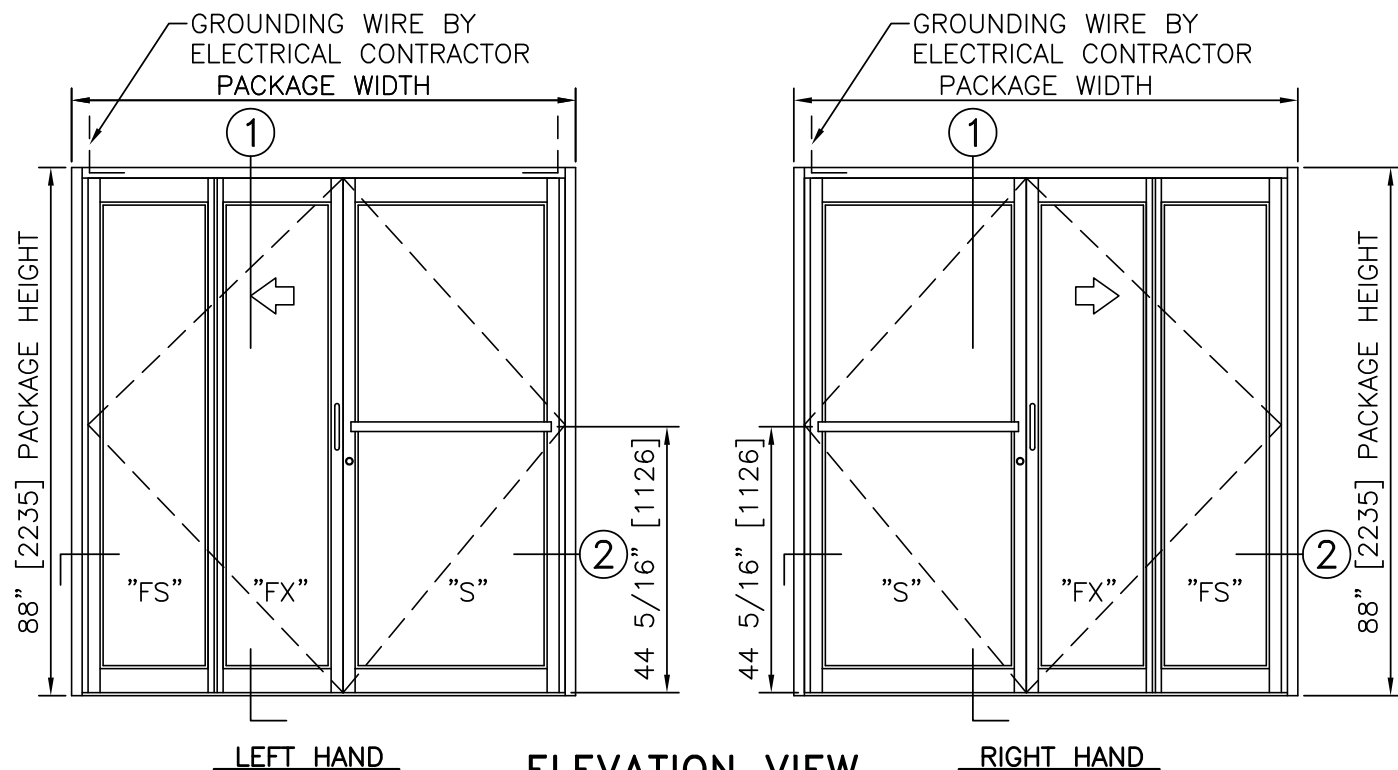

ELEVATION VIEW

SCALE: 3/8" = 1'-0"

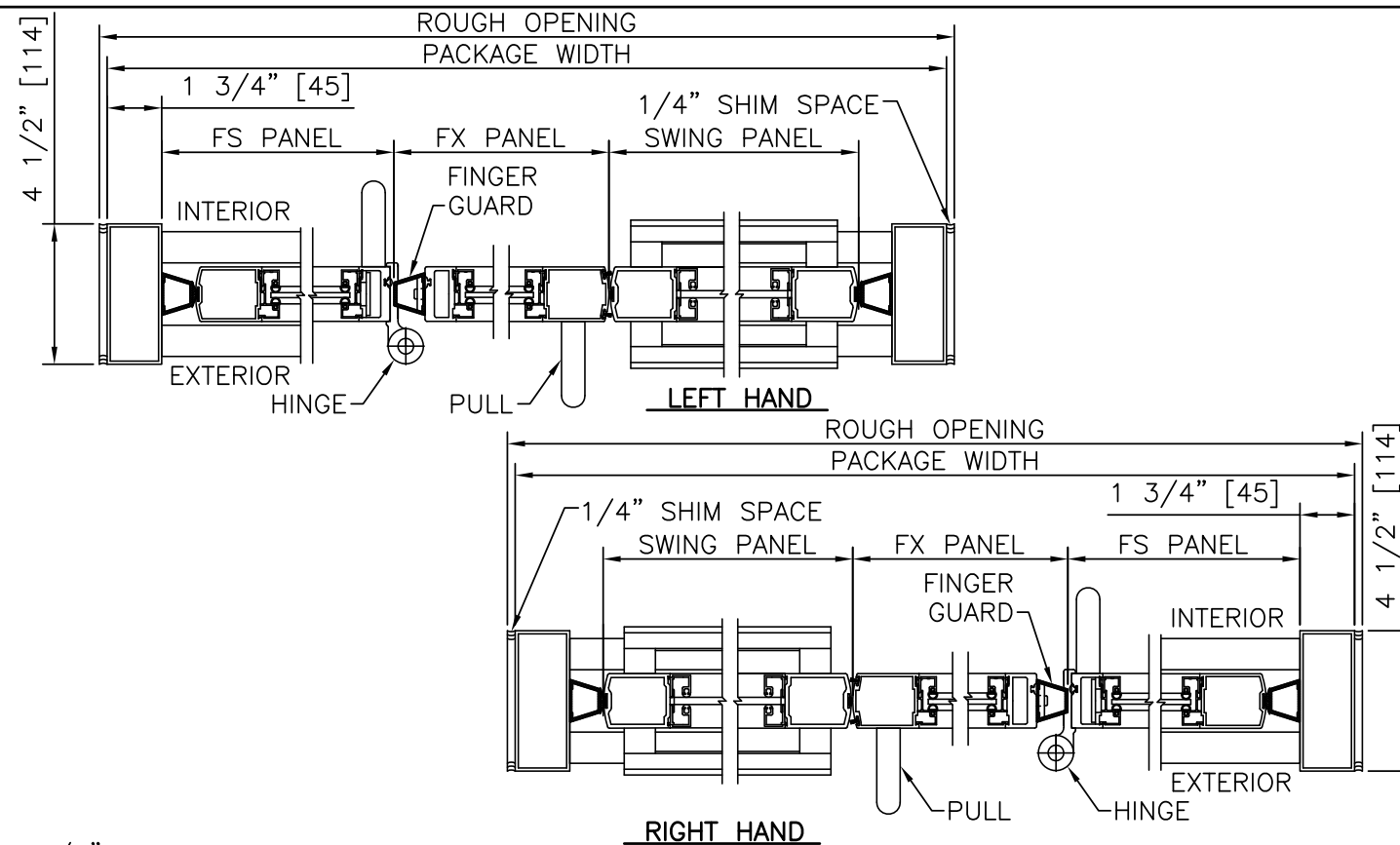

② HORIZONTAL SECTION

SCALE: 2" = 1'-0"

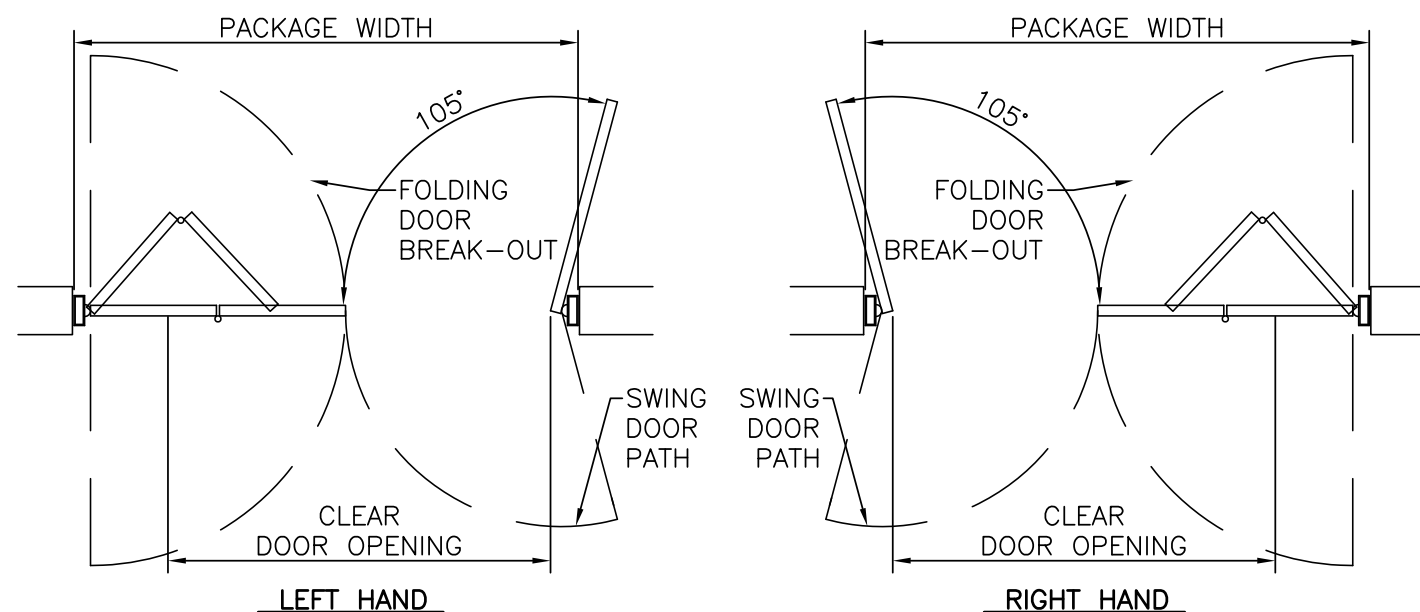

PLAN VIEW

SCALE: 3/8" = 1'-0"

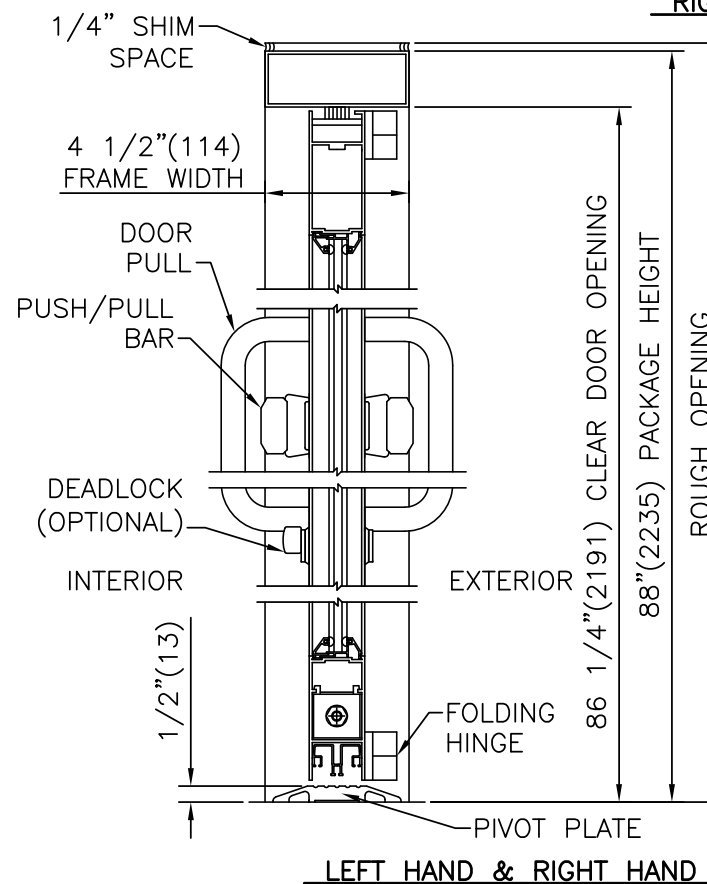

① VERTICAL SECTION

SCALE: 2" = 1'-0"

PRODUCT OPTIONS

- FINISH**
- ANODIZED CLEAR CL2
 - ANODIZED DK BRONZE
 - CUSTOM
- CONFIGURATION**
- FOLD-IN
 - FOLD-OUT
- SWING PANEL**
- 36"
 - 42"
 - 48"
- LOCKING**
- NONE
 - 1-POINT
- BOTTOM RAILS**
- STANDARD 4"
 - OPTIONAL 6" 8" 12"
- MUNTINS**
- OPTIONAL 2" 4 1/4"

7600 FORMULAS
CLEAR DOOR OPENING = PACKAGE WIDTH - 20.3"

- NOTES**
1. PACKAGE SHALL BE GROUNDED TO BUILDING GROUND SYSTEM. GROUNDING WIRE BY ELECTRICAL CONTRACTOR.
 2. ROUGH OPENING SHALL PROVIDE 1/4"[6] SHIM SPACE ON SIDES AND TOP OF PACKAGE.
 3. STANDARD PACKAGE HEIGHT SHOWN, PACKAGE HEIGHTS TO 96"[2438] AVAILABLE.
 4. STANDARD PACKAGE EXCLUDES LOCKING; 1-POINT LOCKING AVAILABLE.
 5. FOLD-IN PACKAGE SHOWN; FOLD-OUT AVAILABLE.
 6. GLAZING STOPS FOR ALL PANELS ARE 1/4"[6].
 7. STANDARD BOTTOM RAILS ARE SHOWN; BOTTOM RAILS TO 12"[305], AND MUNTINS 2"[51] AND 4 1/4"[108] AVAILABLE.
 8. SEE SPECIFICATIONS FOR ADDITIONAL INFORMATION.

TYPICAL PACKAGE DIMENSIONS		
PACKAGE WIDTH	NOMINAL CLEAR DOOR OPENING	SWING DOOR PANEL OPTIONS
84"	63.8"	36", 42", 48"
96"	75.8"	36", 42", 48"
108"	87.8"	42", 48"
120"	99.8"	48"

DURA-CARE™
7600
SERIES

STANLEY
Access Technologies

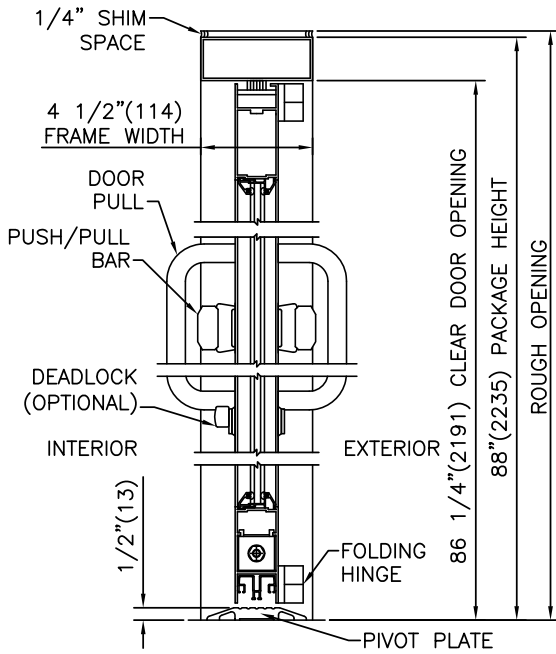

① VERTICAL SECTION

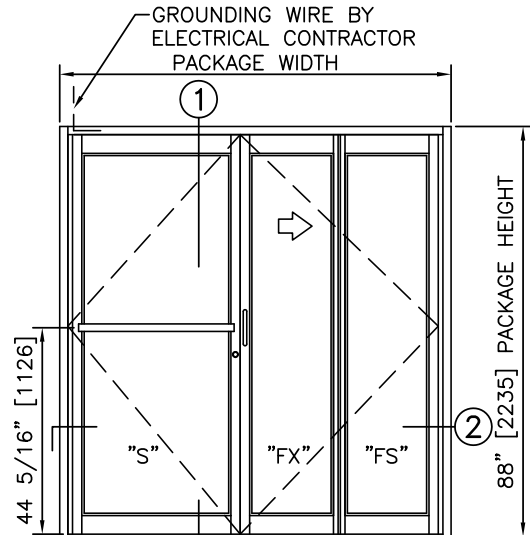

ELEVATION

NOTES

1. PACKAGE SHALL BE GROUNDED TO BUILDING GROUND SYSTEM. GROUNDING WIRE BY ELECTRICAL CONTRACTOR.
2. ROUGH OPENING SHALL PROVIDE 1/4" [6] SHIM SPACE ON SIDES AND TOP OF PACKAGE.
3. STANDARD PACKAGE EXCLUDES LOCKING; 1-POINT LOCKING AVAILABLE.
4. SEE SPECIFICATIONS FOR ADDITIONAL INFORMATION.

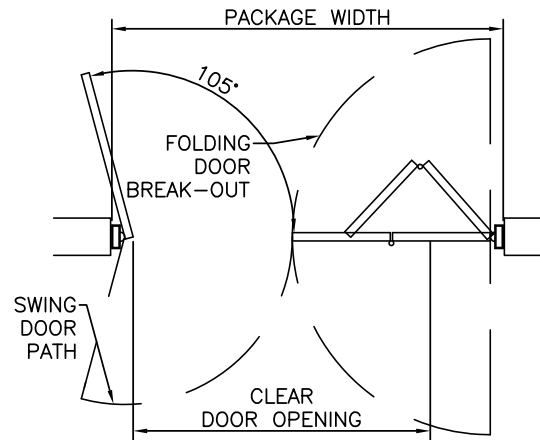

PLAN

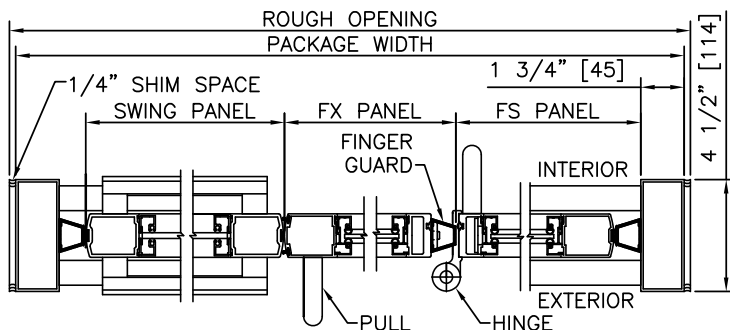

② HORIZONTAL SECTION

TYPICAL PACKAGE DIMENSIONS		
PACKAGE WIDTH	NOMINAL CLEAR DOOR OPENING	SWING DOOR PANEL OPTIONS
84"	63.8"	36", 42", 48"
96"	75.8"	36", 42", 48"
108"	87.8"	42", 48"
120"	99.8"	48"

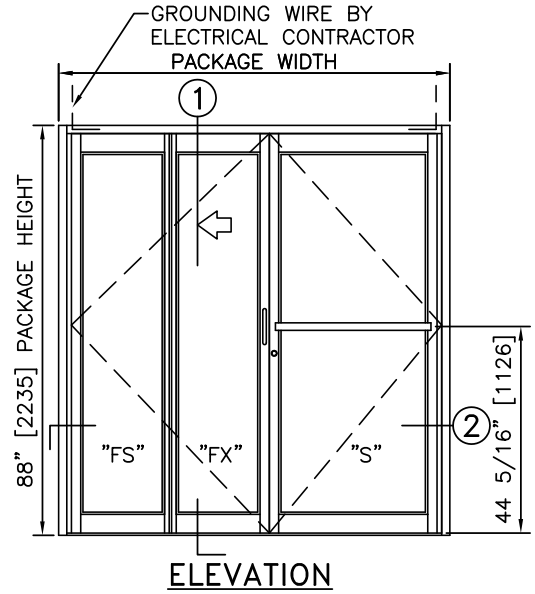
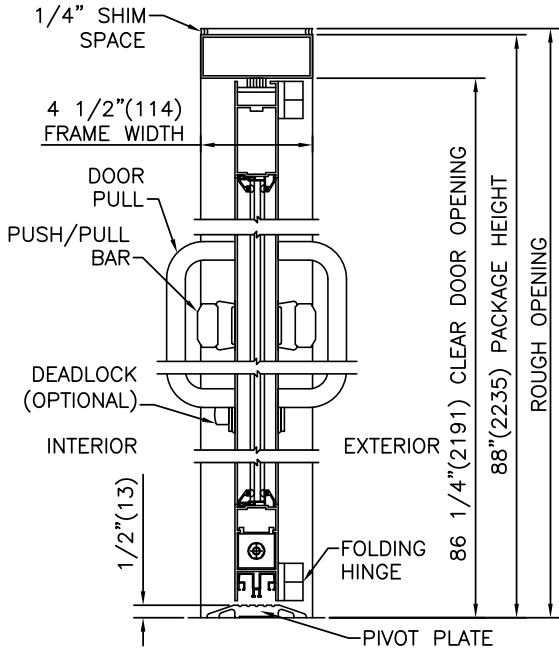

NOTES

1. PACKAGE SHALL BE GROUNDED TO BUILDING GROUND SYSTEM. GROUNDING WIRE BY ELECTRICAL CONTRACTOR.
2. ROUGH OPENING SHALL PROVIDE 1/4" [6] SHIM SPACE ON SIDES AND TOP OF PACKAGE.
3. STANDARD PACKAGE EXCLUDES LOCKING; 1-POINT LOCKING AVAILABLE.
4. SEE SPECIFICATIONS FOR ADDITIONAL INFORMATION.

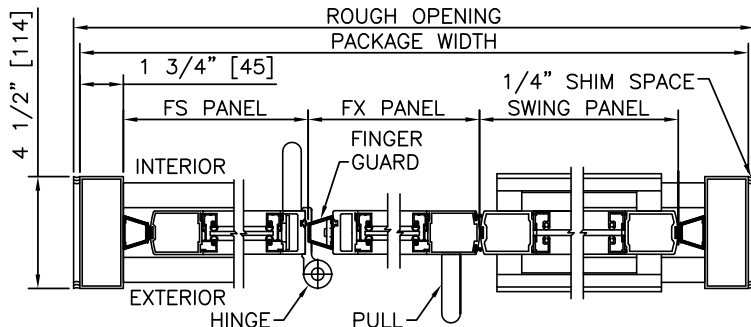
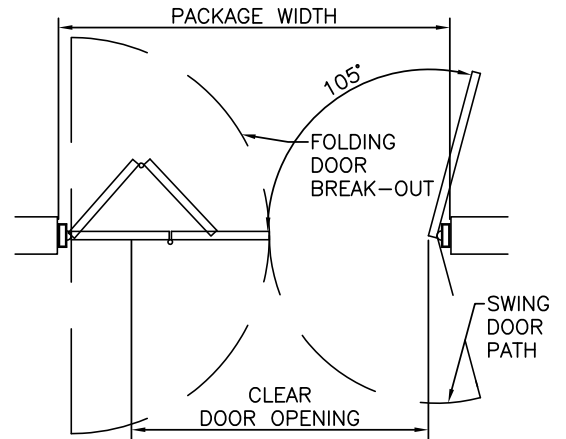

TYPICAL PACKAGE DIMENSIONS		
PACKAGE WIDTH	NOMINAL CLEAR DOOR OPENING	SWING DOOR PANEL OPTIONS
84"	63.8"	36", 42", 48"
96"	75.8"	36", 42", 48"
108"	87.8"	42", 48"
120"	99.8"	48"

DURA-CARE™
7600
SERIES

RIGHT HAND FOLD-OUT

PROJECT INFORMATION

PROJECT NAME:

LOCATION:

DOOR NUMBER(S):

DATE:

SHEET: OF

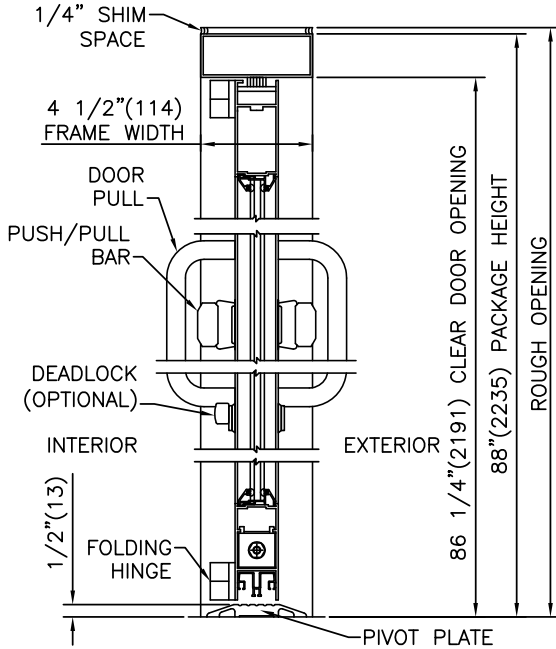

① VERTICAL SECTION

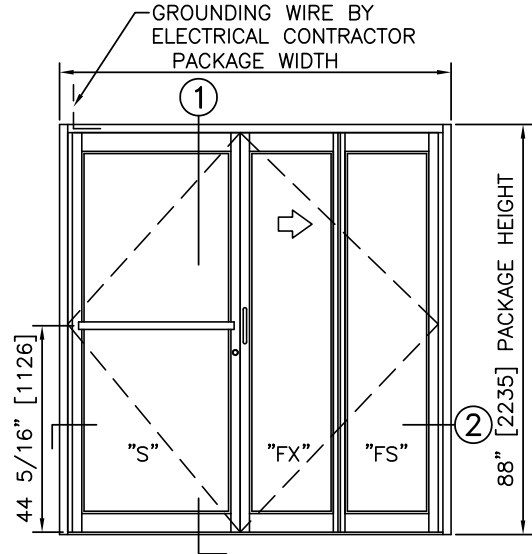

ELEVATION

NOTES

1. PACKAGE SHALL BE GROUNDED TO BUILDING GROUND SYSTEM. GROUNDING WIRE BY ELECTRICAL CONTRACTOR.
2. ROUGH OPENING SHALL PROVIDE 1/4"[6] SHIM SPACE ON SIDES AND TOP OF PACKAGE.
3. STANDARD PACKAGE EXCLUDES LOCKING; 1-POINT LOCKING AVAILABLE.
4. SEE SPECIFICATIONS FOR ADDITIONAL INFORMATION.

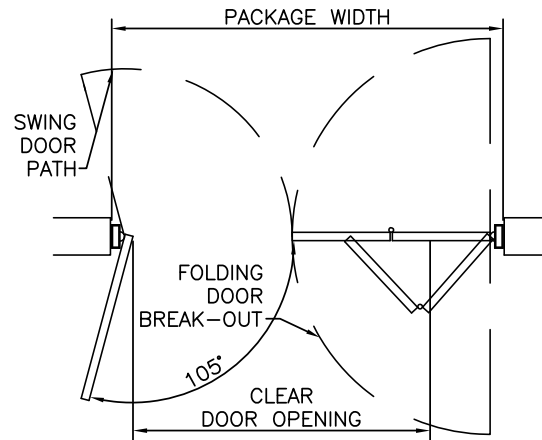

PLAN

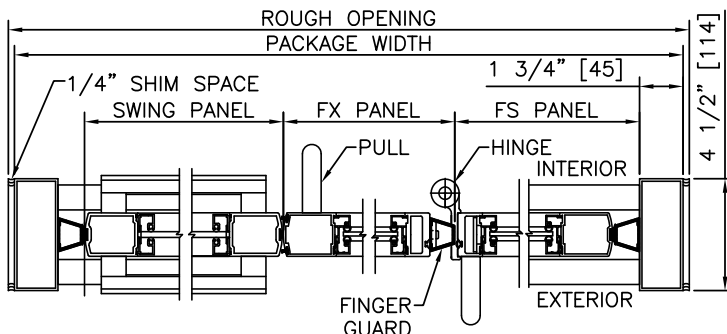

② HORIZONTAL SECTION

TYPICAL PACKAGE DIMENSIONS		
PACKAGE WIDTH	NOMINAL CLEAR DOOR OPENING	SWING DOOR PANEL OPTIONS
84"	63.8"	36", 42", 48"
96"	75.8"	36", 42", 48"
108"	87.8"	42", 48"
120"	99.8"	48"

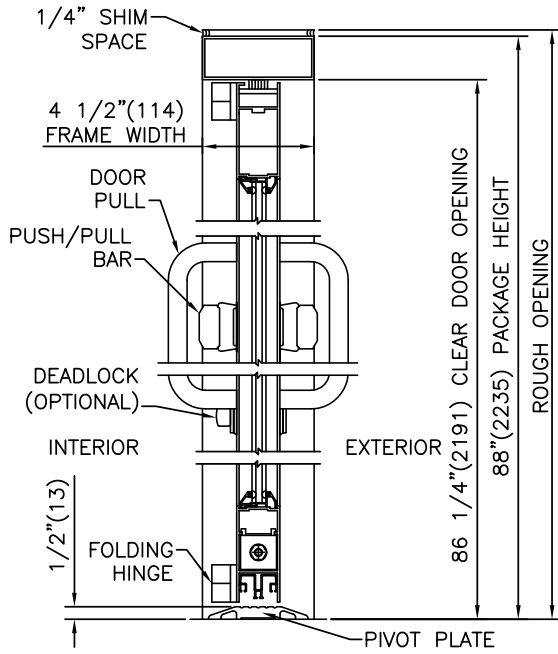

① VERTICAL SECTION

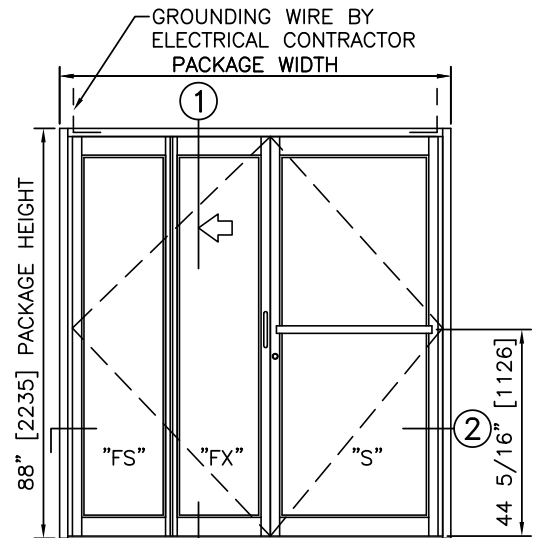

ELEVATION

NOTES

1. PACKAGE SHALL BE GROUNDED TO BUILDING GROUND SYSTEM. GROUNDING WIRE BY ELECTRICAL CONTRACTOR.
2. ROUGH OPENING SHALL PROVIDE 1/4" [6] SHIM SPACE ON SIDES AND TOP OF PACKAGE.
3. STANDARD PACKAGE EXCLUDES LOCKING; 1-POINT LOCKING AVAILABLE.
4. SEE SPECIFICATIONS FOR ADDITIONAL INFORMATION.

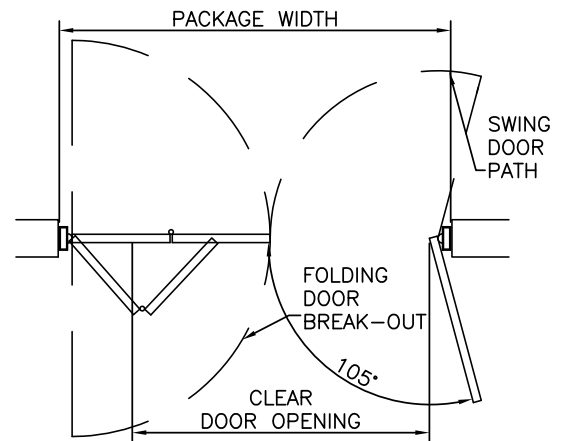

PLAN

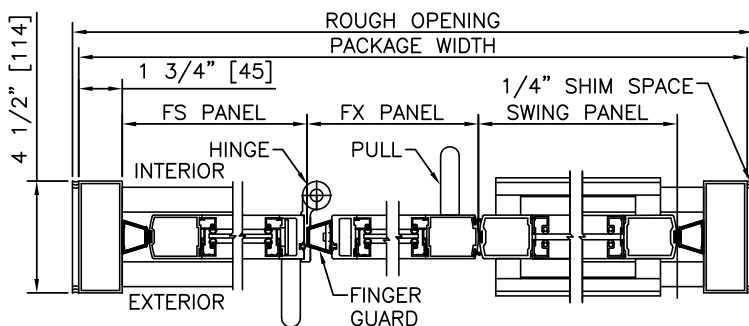

② HORIZONTAL SECTION

TYPICAL PACKAGE DIMENSIONS		
PACKAGE WIDTH	NOMINAL CLEAR DOOR OPENING	SWING DOOR PANEL OPTIONS
84"	63.8"	36", 42", 48"
96"	75.8"	36", 42", 48"
108"	87.8"	42", 48"
120"	99.8"	48"