



 **Swing Doors**



## Stanley Rush Swing Doors



HIGH QUALITY SWING DOORS DESIGNED FOR LONG LASTING PERFORMANCE  
IN HIGH TRAFFIC AREAS

- Concealed door closer
- Snap on covers with no visible screws in framing
- Tempered glass doors
- Concealed in header, access controlled operator with push buttons
- Custom dimensions available in many sizes
- Transom and sidelite options available



### STANLEY Rush Products Group

65 Riviera Drive  
Markham, ON, L3R 5J6  
(T) 905-944-8005  
(F) 905-944-8006

StanleyRush@sbdinc.com  
[www.stanleyrush.com](http://www.stanleyrush.com)

# Stanley Rush Swing Doors

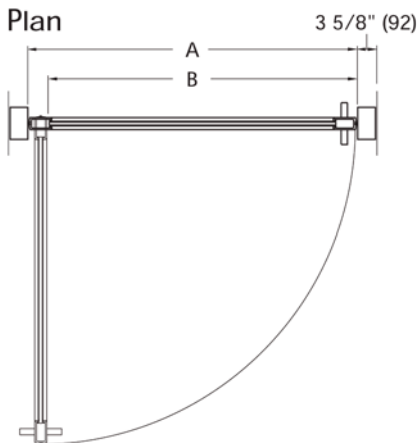

## Features

- Series 10, 30, 40, 60 available
- Heavy duty door closers
- Standard handles
- 1/4" (6 mm) tempered glass for far
- Custom dimensions available in many sizes
- 1/2" (12 mm) laminated glass for all glass doors

## Options

- Center pivot, hinged or offset pivot
- Locking
- Panic exit devices
- Automatic operators - Stanley magic force
- Optional handles
- Special glass

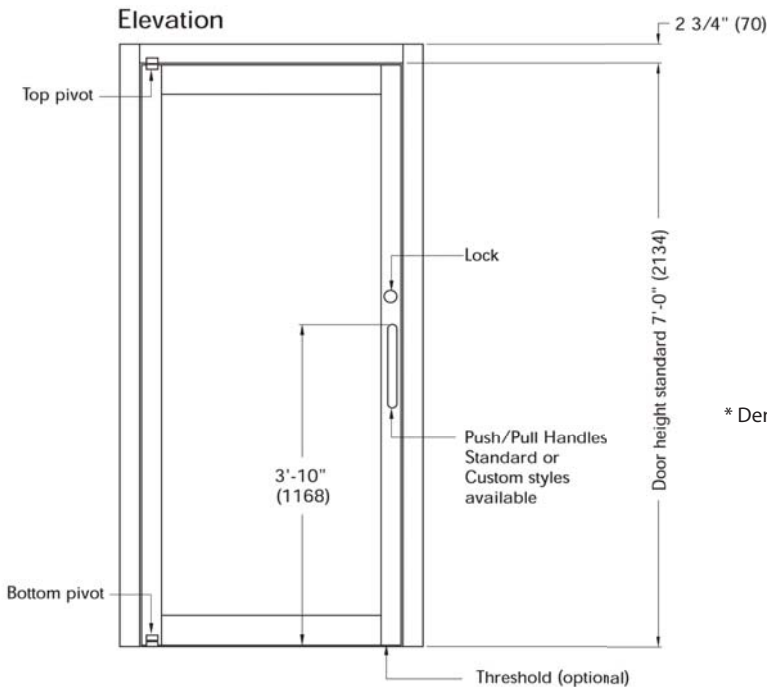

Standard Door Dimensions	
A - Door Opening Width	B - Clear Opening Width
* 3' - 0" (914)	2'-8 3/8" (822)
* 3' - 6" (1067)	3'-2 3/8" (975)

Custom Dimensions are available in almost any size.

\* Denotes standard size doors in 7'-0" (2134) height. All other sizes and heights are custom fabricated and finished to suit specific job requirements.



## STANLEY Rush Products Group

65 Riviera Drive  
Markham, ON, L3R 5J6  
(T) 905-944-8005  
(F) 905-944-8006

StanleyRush-sales@sbdinc.com  
www.stanleyrush.com



## Swing Doors

Complementary to the fine line of door styles and entrance components, Stanley Rush offers pivot or hinged doors in a variety of finishes and quality craftsmanship for which Stanley Rush is known.

### Features

- Door closer overhead concealed
- Tempered glass doors
- Heavy extruded corner and bearing bracket
- Snap on covers with no visible screws

### Options

- Centre pivot (concealed)
- Offset pivot (exposed)
- Hinged doors
- Virtually any special hardware requirements can be applied as required
- Stanley Magic Force operator for handicapped access

### Explanation of Swing Door Series

When specifying swing doors, the first two digits represent the frame type and the last two digits represent the door type.

### Framing

**2000 Series:** Conventional 2 ¾" x 5" framing with snap-on cover plates to eliminate exposed fasteners

### Doors

**10 Series:** Wide stile (refer to balanced door section for framing sizes). ¼" tempered glass required

**30 Series:** Narrow stile. ½" tempered glass required

**40 Series:** Medium stile. ½" tempered glass required

**60 Series:** Top and bottom rails only – all glass look. ½" tempered glass required



*Mole White & Associates Ltd.*

#2010 Series  
Custom Swing Door

Satin Bronze Finish

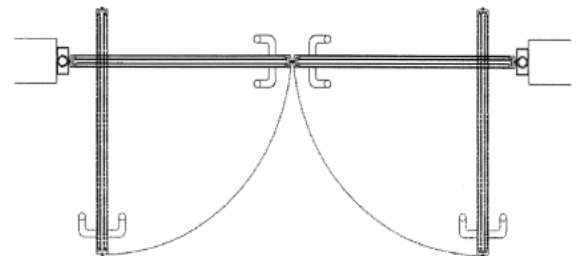



*Webb Zerafa Menkes Housden*

Replica 1920 Custom Entrance  
#1500 Series Revolving Door  
#2010 Series Offset Pivot Doors  
Curved Sliding Night/Security Screens  
Glass Canopy, Stainless Steel Finish Grill,  
Bronze Plaques

Satin Stainless Steel Finish

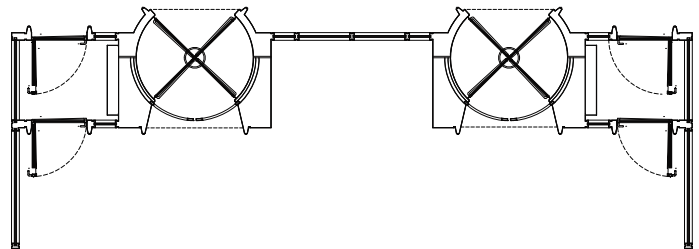



#2060 Series Pivot Door  
Mirror Stainless Steel Finish

