

MODEL NO.	A±.031
2036	42
2042	48
2044	50
2048	54
2248	30
2260	36
2272	42

REV.	BY	DATE	PCN #	DESCRIPTION
A	TJS	9-9-96	96-1-8	INITIAL RELEASE
B	BNW	5-11-98	98-21	1-4-20 WAS 12-24
C	JPK vlt	2-7-00	99-89	REDRAWN IN PRO-E DEL. 7/16 DIA., 2.5/16 DIA., 9/16 DIA. AND 5/8 DIA.

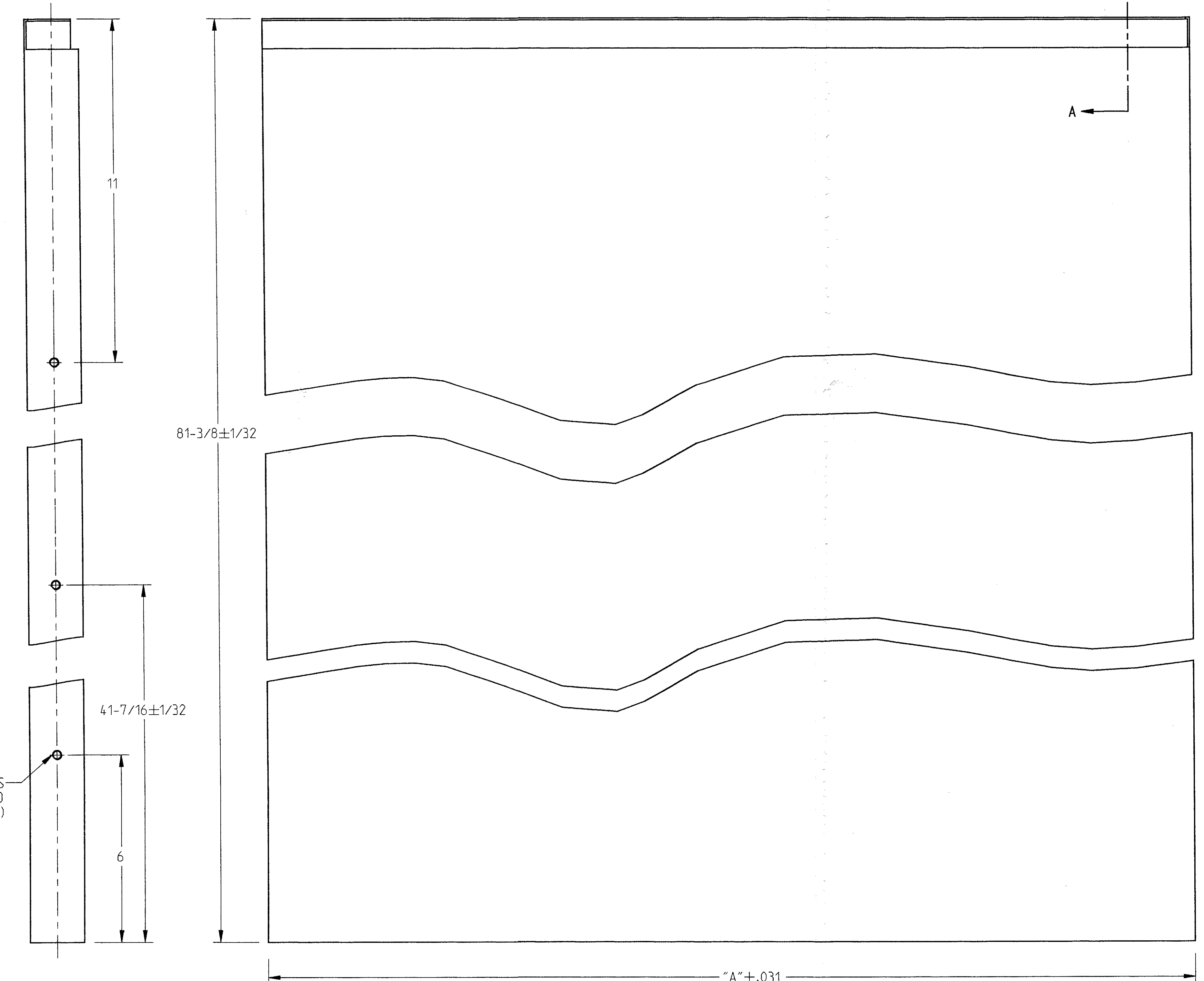
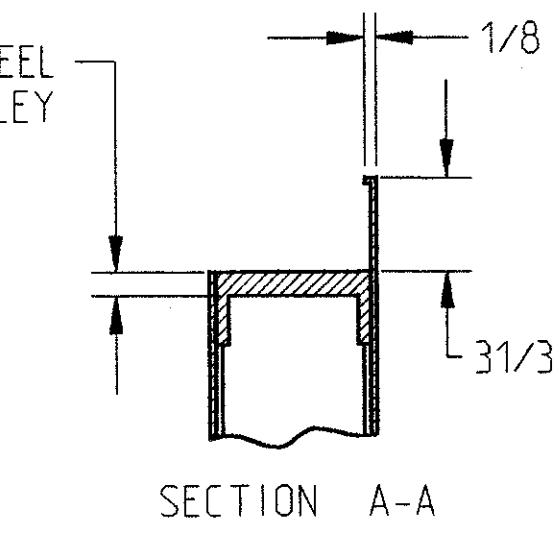
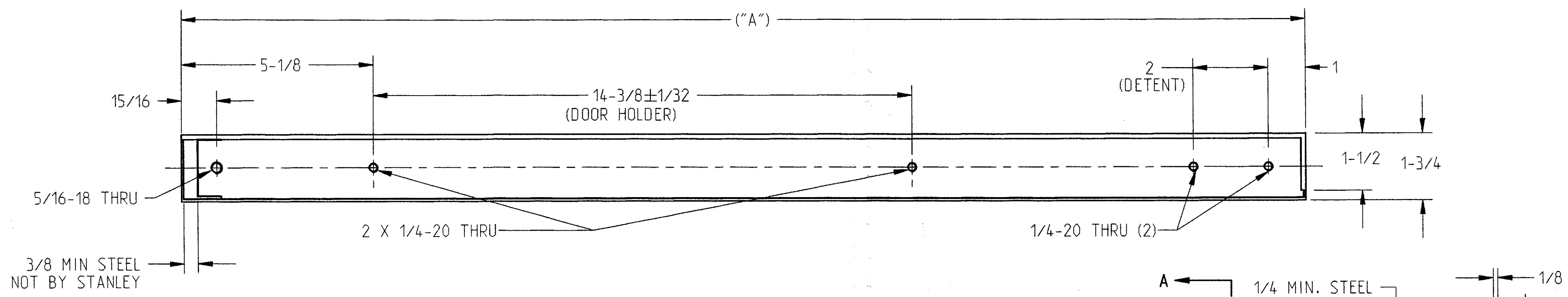

5/16-18 THRU (3) HOLES
REF. 3/4 LONG BUTTON HD
HEX SOC SCREWS (3)

Pro/ENGINEER File		STANLEY		CONFIDENTIAL - This document and all information contained herein is the property of The Stanley Works and may not be disclosed to unauthorized persons or reproduced by any means, or used for any purpose other than that submitted without express written permission from The Stanley Works.	
Drawn by:	Date:	ACCESS TECHNOLOGIES		Designed by:	Scale: (except as noted)
T.J.S.	9-9-96			T.J.S.	2-4-00 1:2
Checked by:	Date:	Tolerances: (except as noted)		Material:	Finish:
J.ROBIDA	10-21-96	.X: 0.1			
Approved by:	Date:	.XX: 0.01			
P.LOMBARDO	10-21-96	.XXX: 0.015			
Project:		ANGLES: 1.0			
DURA-GLIDE 2000 DESIGNER		Project Number:	TITLE: SX RH HOLLOW METAL PANEL PREPARATION DRAWING		
SURFACE FINISH: <input checked="" type="checkbox"/> BREAk SHARP EDGES .01		Part Number:	Drawing Number:		
		110860	110860		
			Rev:	Sheet:	
			C	1 OF 1	