



## MANUAL SLIDING ICU DOORS: DURA-CARE™ 7200 SERIES, BI-PARTING

### 3.05 - BI-PARTING WITH OPTIONAL TRANSOM

- 3.05.01 - BI-PARTING, TRACKLESS
- 3.05.02 - BI-PARTING, TRACKLESS, SURFACE APPLIED



# DURA-CARE™ 7200 SERIES

<b>BI-PART TRACKLESS</b>	
PROJECT INFORMATION	
PROJECT NAME:	
LOCATION:	
DOOR NUMBER(S):	
DATE:	SHEET: OF

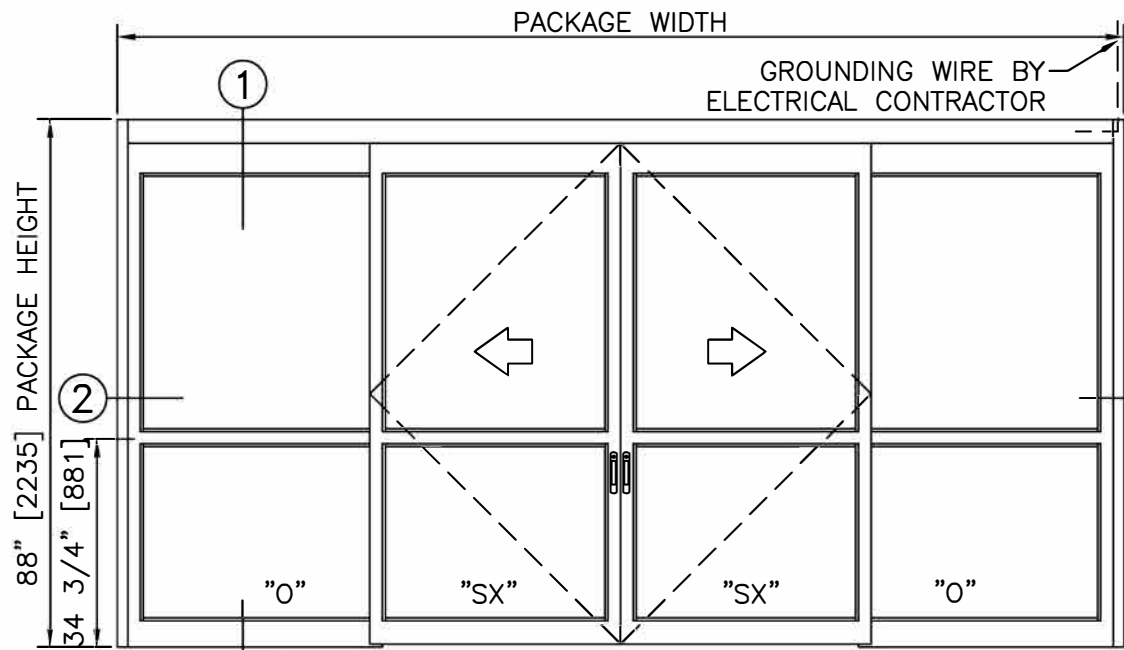

**ELEVATION VIEW**  
SCALE: 3/8" = 1'-0"

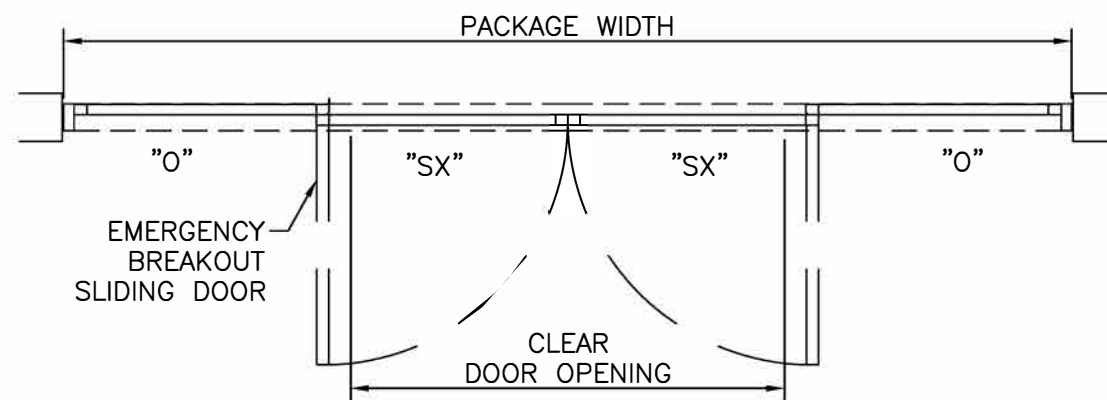

**PLAN VIEW**  
SCALE: 3/8" = 1'-0"

- NOTES**
1. PACKAGE SHALL BE GROUNDED TO BUILDING GROUND SYSTEM. GROUNDING WIRE BY ELECTRICAL CONTRACTOR.
  2. ROUGH OPENING SHALL PROVIDE 1/4"[6] SHIM SPACE ON SIDES AND TOP OF PACKAGE.
  3. STANDARD PACKAGE EXCLUDES LATCHING OR LOCKING. LOCKING SYSTEMS AVAILABLE.
  4. STANDARD GLAZING STOPS FOR ALL PANELS ARE 1/4"[6]; 5/8"[16] AND 1"[25] AVAILABLE.
  5. STANDARD JAMB TUBES SHOWN; 6"[152] AVAILABLE.
  6. STANDARD STILES, BOTTOM RAILS AND MUNTINS SHOWN; MEDIUM STILES, BOTTOM RAILS TO 12"[305], AND 4 1/4"[108] MUNTINS AVAILABLE.
  7. SEE SPECIFICATIONS FOR ADDITIONAL INFORMATION.

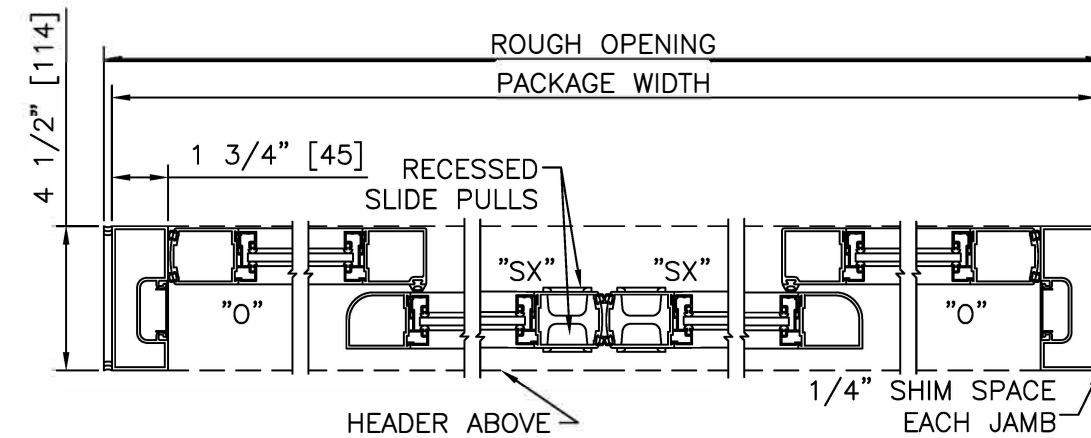

**HORIZONTAL SECTION**  
SCALE: 2" = 1'-0"

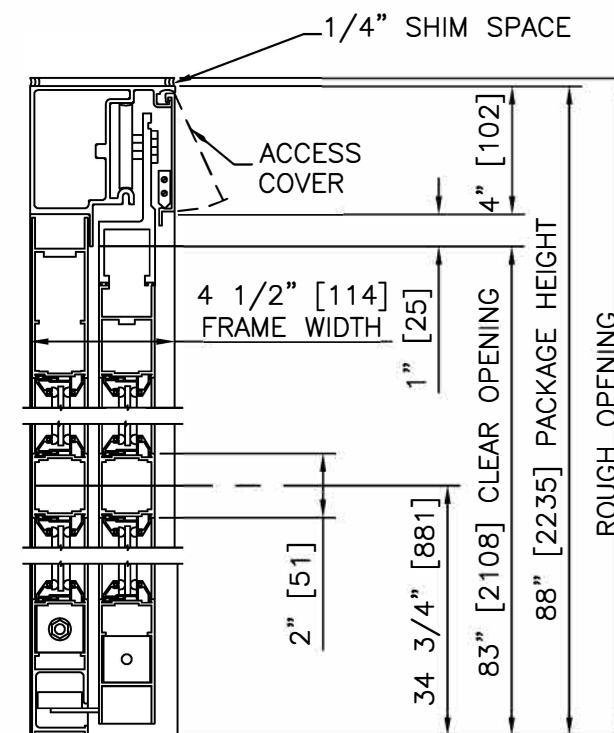

**LEFT HAND & RIGHT HAND**  
**VERTICAL SECTION**  
SCALE: 2" = 1'-0"

**PRODUCT OPTIONS**

- FINISH**
- ANODIZED CLEAR CL2
  - ANODIZED DK BRONZE
  - CUSTOM
- LATCHING/LOCKING**
- 1-POINT
  - 2-POINT
  - 3-POINT
- STILES**
- NARROW
  - MEDIUM
- BOTTOM RAILS**
- STANDARD 4"
  - OPTIONAL 6" 8" 10" 12"
- THRESHOLDS**
- SQ/BVL (EXT)
  - SQ/BVL (INT)
  - DBL BVL
  - RECESSED

- BI-PART FORMULAS - NARROW STILE**
- PACKAGE WIDTH = 2 X CLEAR DOOR OPENING + 23.4"
  - CLEAR DOOR OPENING = 1/2 PACKAGE WIDTH - 11.7"
  - EMERGENCY BREAKOUT WIDTH = CLEAR DOOR OPENING + 7.3"
  - DOOR PANEL WIDTH = 1/4 PACKAGE WIDTH + 0.3"
- BI-PART FORMULAS - MEDIUM STILE**
- PACKAGE WIDTH = 2 X CLEAR DOOR OPENING + 32.1"
  - CLEAR DOOR OPENING = 1/2 PACKAGE WIDTH - 16.0"
  - EMERGENCY BREAKOUT WIDTH = CLEAR DOOR OPENING + 10.3"
  - DOOR PANEL WIDTH = 1/4 PACKAGE WIDTH + 1.1"

TYPICAL PACKAGE DIMENSIONS (NARROW STILE)			
PACKAGE WIDTH	NOMINAL CLEAR DOOR OPENING	DOOR PANEL NOMINAL WIDTH	EMERGENCY BREAKOUT NOM. WIDTH
120"	48.3"	30.3"	55.6"
144"	60.3"	36.3"	67.6"
168"	72.3"	42.3"	79.6"

<b>BI-PART TRACKLESS</b>	
<b>DURA-CARE™ 7200 SERIES</b>	<b>STANLEY Security ACCESS TECHNOLOGIES</b>

**DURA-CARE™**  
**7200**  
**SERIES**

BI-PART TRACKLESS

PROJECT INFORMATION

PROJECT NAME:

LOCATION:

DOOR NUMBER(S):

DATE:

SHEET: OF

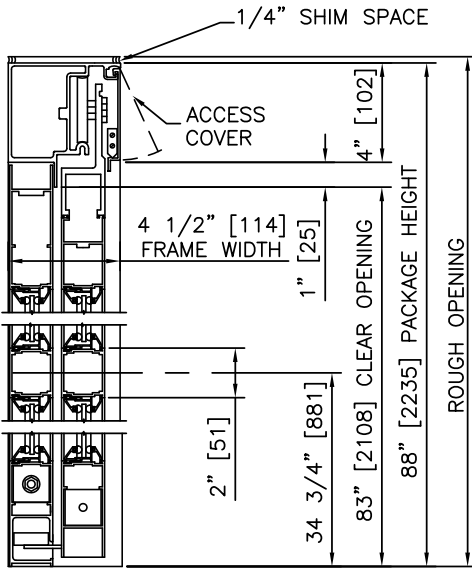

1 VERTICAL SECTION

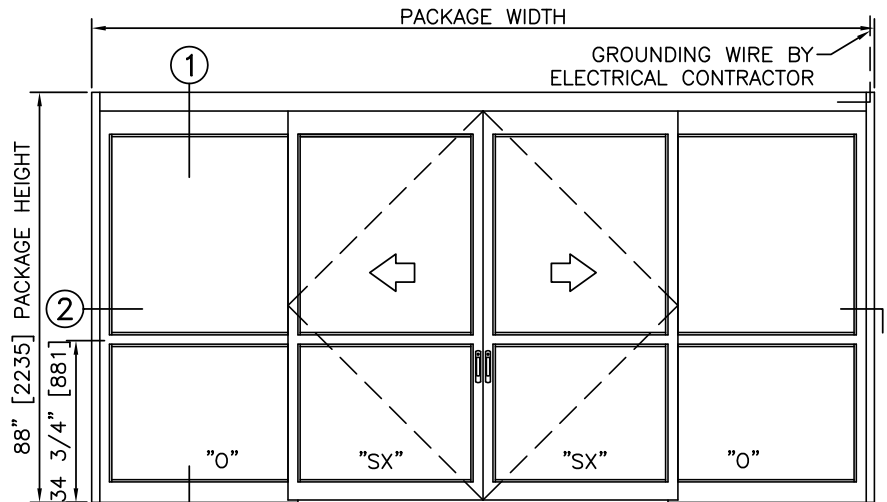

ELEVATION

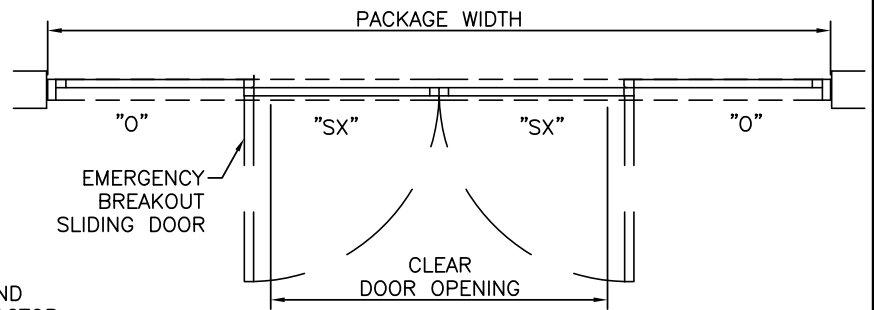

PLAN

NOTES

1. PACKAGE SHALL BE GROUNDED TO BUILDING GROUND SYSTEM. GROUNDING WIRE BY ELECTRICAL CONTRACTOR.
2. ROUGH OPENING SHALL PROVIDE 1/4" [6] SHIM SPACE ON SIDES AND TOP OF PACKAGE.
3. STANDARD PACKAGE EXCLUDES LATCHING OR LOCKING. LOCKING SYSTEMS AVAILABLE.
4. SEE SPECIFICATIONS FOR ADDITIONAL INFORMATION.

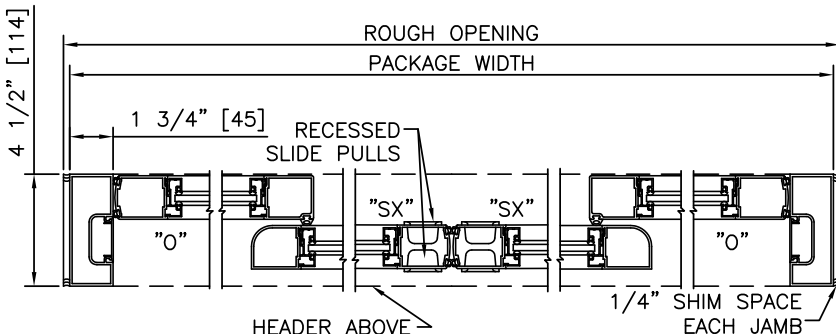

2 HORIZONTAL SECTION

TYPICAL PACKAGE DIMENSIONS (NARROW STILE)			
PACKAGE WIDTH	NOMINAL CLEAR DOOR OPENING	DOOR PANEL NOMINAL WIDTH	EMERGENCY BREAKOUT NOM. WIDTH
120"	48.3"	30.3"	55.6"
144"	60.3"	36.3"	67.6"
168"	72.3"	42.3"	79.6"

**DURA-CARE™**  
**7200**  
**SERIES**

BI-PART TRACKLESS, SURFACE APPLIED

PROJECT INFORMATION

PROJECT NAME:

LOCATION:

DOOR NUMBER(S):

DATE:

SHEET: OF

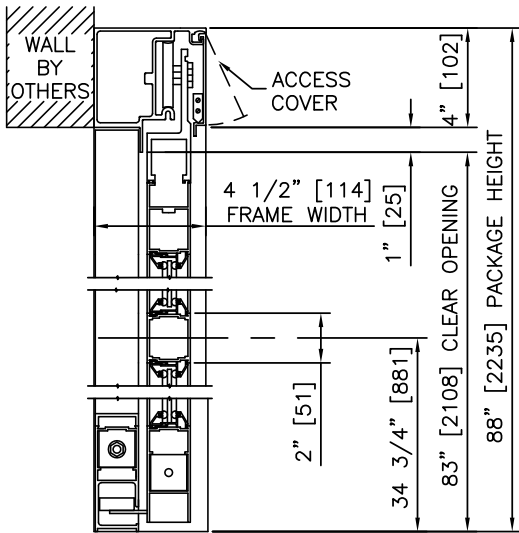

1 VERTICAL SECTION

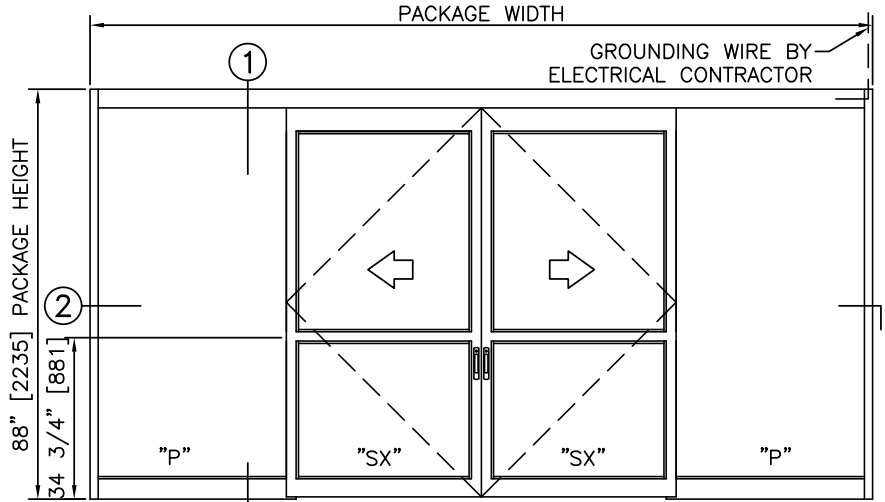

ELEVATION

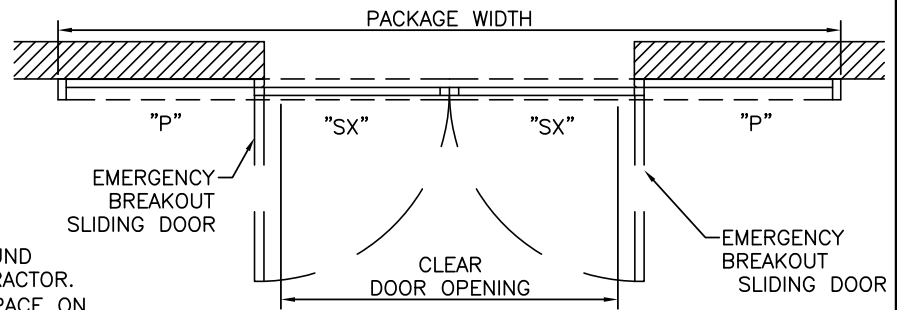

PLAN

NOTES

1. PACKAGE SHALL BE GROUNDED TO BUILDING GROUND SYSTEM. GROUNDING WIRE BY ELECTRICAL CONTRACTOR.
2. ROUGH OPENING SHALL PROVIDE 1/4" [6] SHIM SPACE ON SIDES AND TOP OF PACKAGE.
3. STANDARD PACKAGE EXCLUDES LATCHING OR LOCKING. LOCKING SYSTEMS AVAILABLE.
4. SEE SPECIFICATIONS FOR ADDITIONAL INFORMATION.

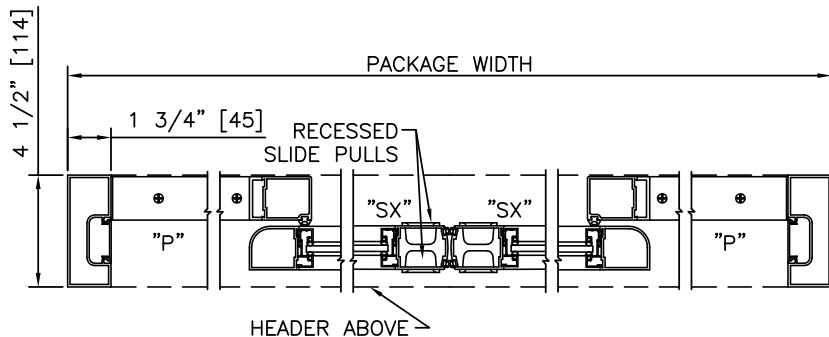

2 HORIZONTAL SECTION

TYPICAL PACKAGE DIMENSIONS (NARROW STILE)			
PACKAGE WIDTH	NOMINAL CLEAR DOOR OPENING	DOOR PANEL NOMINAL WIDTH	EMERGENCY BREAKOUT NOM. WIDTH
120"	48.3"	30.3"	55.6"
144"	60.3"	36.3"	67.6"
168"	72.3"	42.3"	79.6"