



## SLIDING AUTOMATIC ENTRANCES: DURA-STORM™ 3000 IMPACT STEEL REINFORCED

### 2.10 - BI-PARTING

- 2.10.01 - BI-PARTING
- 2.10.02 - BI-PARTING WITH AUTOMATIC LOCKING



# DURA-STORM 3000 IMPACT SERIES

BI-PART, STEEL REINFORCED	
PROJECT INFORMATION	
PROJECT NAME:	
LOCATION:	
DOOR NUMBER(S):	
DATE:	SHEET: OF

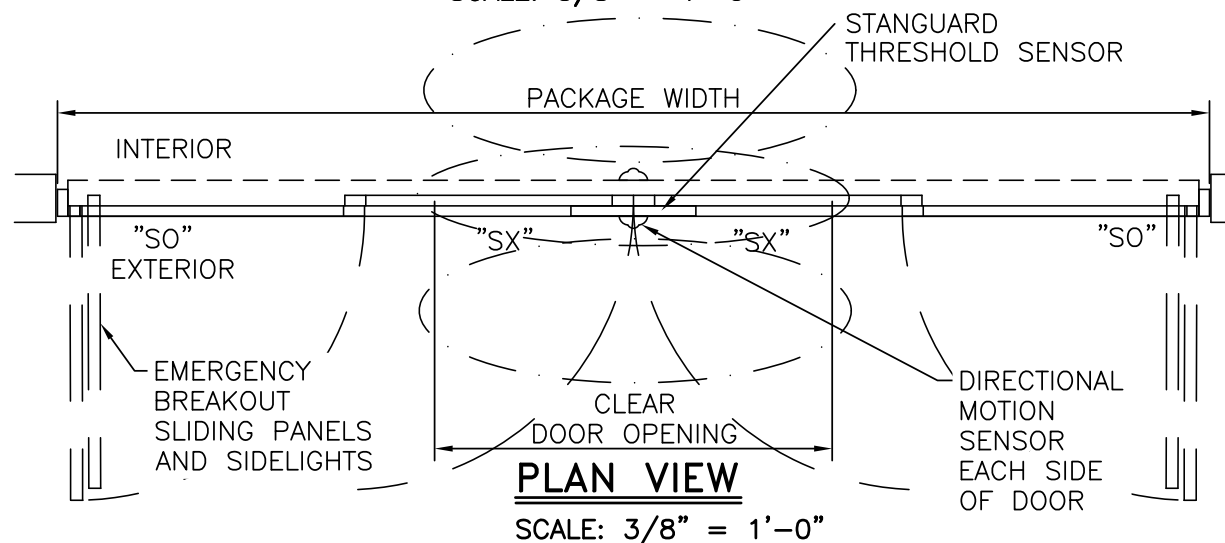
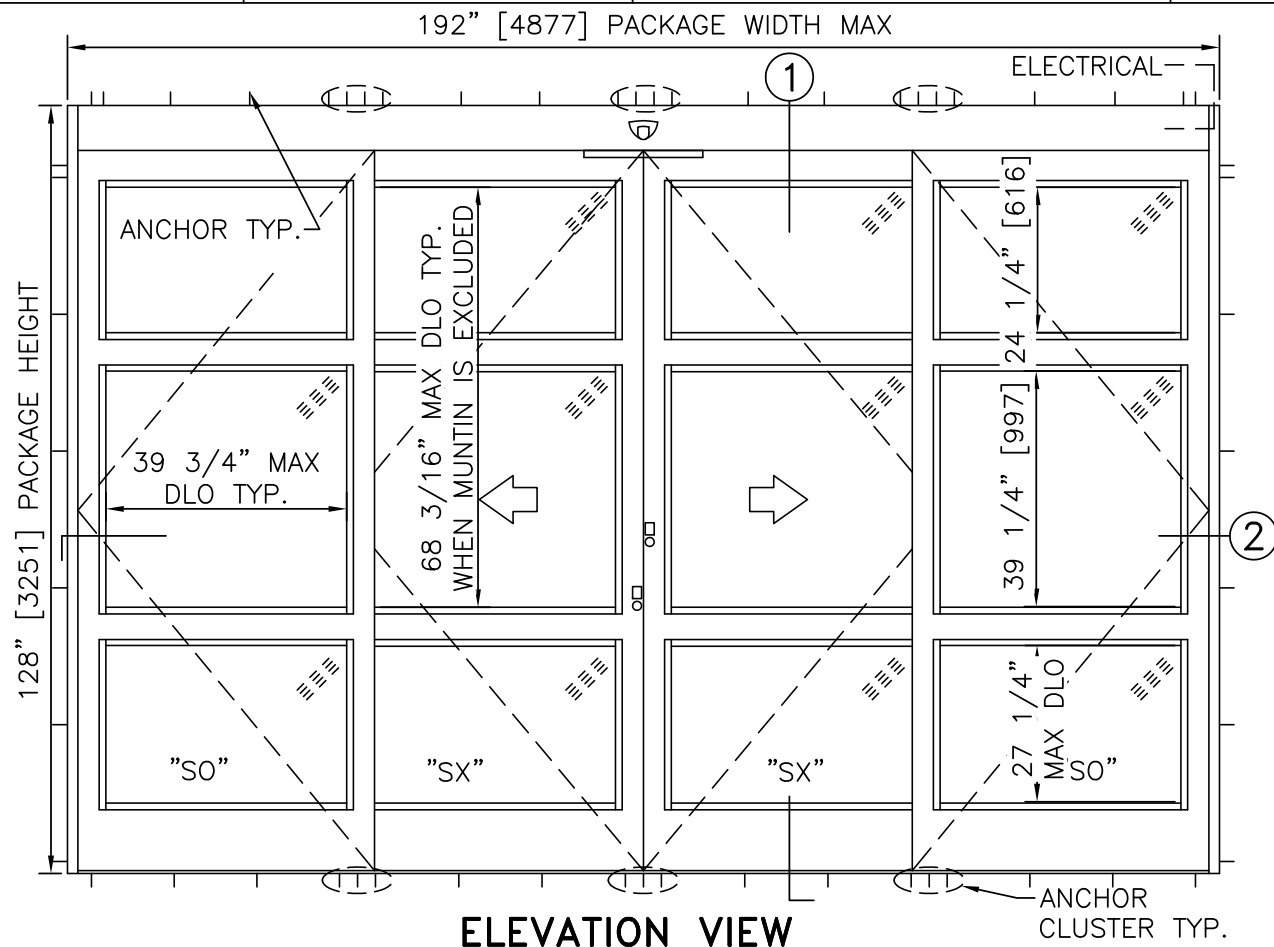

- NOTES**
- ELECTRICAL REQUIREMENTS: 120 VAC, 5 AMP MIN TO POWER OPERATOR BY ELECTRICAL CONTRACTOR.
  - ROUGH OPENING SHALL PROVIDE 1/4"[6] SHIM SPACE ON SIDES AND TOP OF PACKAGE.
  - ACTIVATION AND SAFETY ZONES ARE FOR REFERENCE ONLY; SEE ANSI/BHMA A156.10 FOR DETAILED REQUIREMENTS.
  - 5-POINT LOCKING STANDARD. ELECTRIC SOLENOID LOCK MAY BE ADDED FOR ACCESS CONTROL.
  - ENTRANCE TO RECEIVE APPROVED 9/16"[14] LAMINATED GLAZING.
  - STANDARD STILES, BOTTOM RAILS AND MUNTINS SHOWN; MEDIUM STILES, BOTTOM RAILS TO 10"[254], AND 4 1/4"[108] MUNTINS AVAILABLE.
  - PRODUCT SHALL BE MANUFACTURED AND INSTALLED IN ACCORDANCE WITH PRODUCT APPROVALS; SEE MIAMI-DADE COUNTY NOTICE OF ACCEPTANCE OR FLORIDA BUILDING CODE APPROVAL
  - SEE SPECIFICATIONS FOR ADDITIONAL INFORMATION.

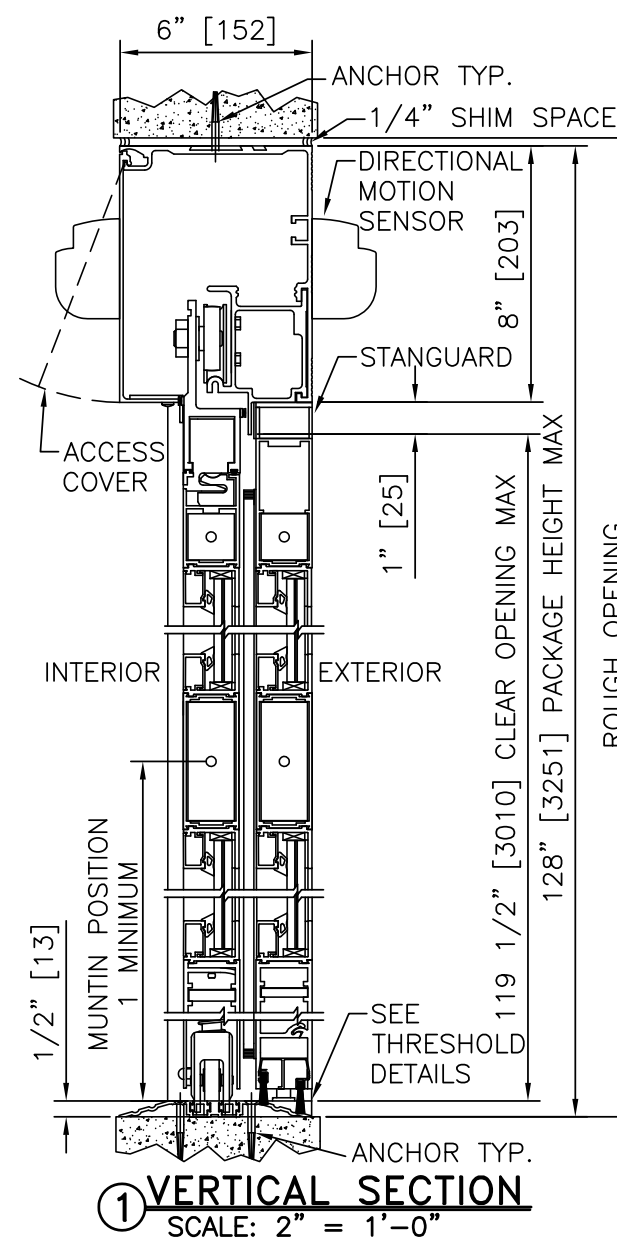
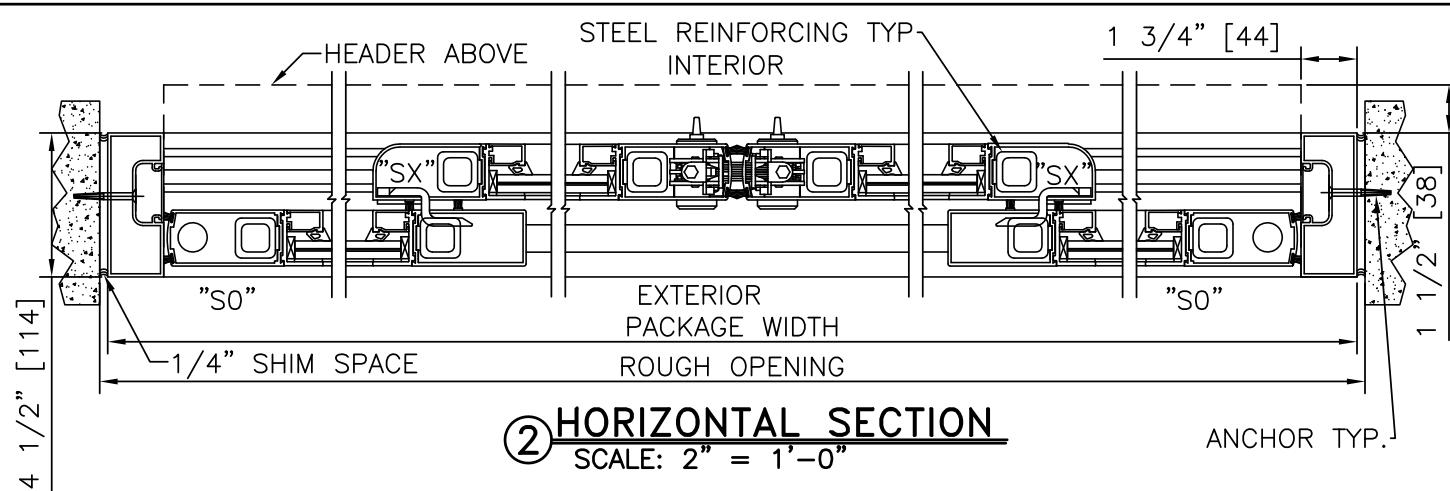

### PRODUCT OPTIONS

- FINISH**
- ANODIZED CLEAR CL2
  - ANODIZED DK BRONZE
  - CUSTOM
- LOCKING**
- 5-POINT
  - ELECTRIC SOLENOID LOCK
- STILES**
- MEDIUM
- MUNTINS**
- 1  2
- JAMBS**
- 4 1/2"  6"
- BOTTOM RAILS**
- STANDARD 10"
- THRESHOLDS**
- SQ/BVL (EXT)  SQ/BVL (INT)
  - DBL BVL  RECESSED
- ACTIVATION/SAFETY**
- 2 SU-100/STANGUARD
  - 2 COMBINED ATIVATION/SAFETY SENSORS
- OTHER OPTIONS**
- ROTARY CTRL SWITCH  KEYED
  - UNINTERRUPTIBLE POWER SUPPLY
  - FLY OPEN BOX
  - WIND DAMPERS
  - ALARM CONTACTS

MAX. PACKAGE DIMENSIONS (MEDIUM STILE)				
PACKAGE WIDTH	NOMINAL CLEAR DOOR OPENING	DOOR PANEL NOMINAL WIDTH	EMERGENCY BREAKOUT NOM. WIDTH	PACKAGE HEIGHT MAX AT PACKAGE WIDTH
179.5"	72.0"	46.3"	162.0"	128.0"
192.0"	78.3"	49.4"	174.5"	104.0"

DESIGN RATINGS	
MISSILE IMPACT RATING	
<input checked="" type="checkbox"/>	LARGE AND SMALL MISSILE IMPACT
DESIGN PRESSURE RATING (PSF[Pa])	
POSITIVE	55 PSF [2633 Pa]
NEGATIVE	55 PSF [2633 Pa]

**BI-PART, STEEL REINFORCED**

**DURA-STORM**

**3000**

**IMPACT**

**SERIES**

**BI-PART FORMULAS -- MEDIUM STILE**  
 PACKAGE WIDTH = 2 X CLEAR DOOR OPENING + 35.5"  
 CLEAR DOOR OPENING = 1/2 PACKAGE WIDTH - 17.8"  
 EMERGENCY BREAKOUT WIDTH = PACKAGE WIDTH - 17.5"  
 DOOR PANEL WIDTH = 1/4 PACKAGE WIDTH + 1.4"

## DURA-STORM 3000 IMPACT SERIES

BI-PARTING

PROJECT INFORMATION

PROJECT NAME:

LOCATION:

DOOR NUMBER(S):

DATE:

SHEET: OF

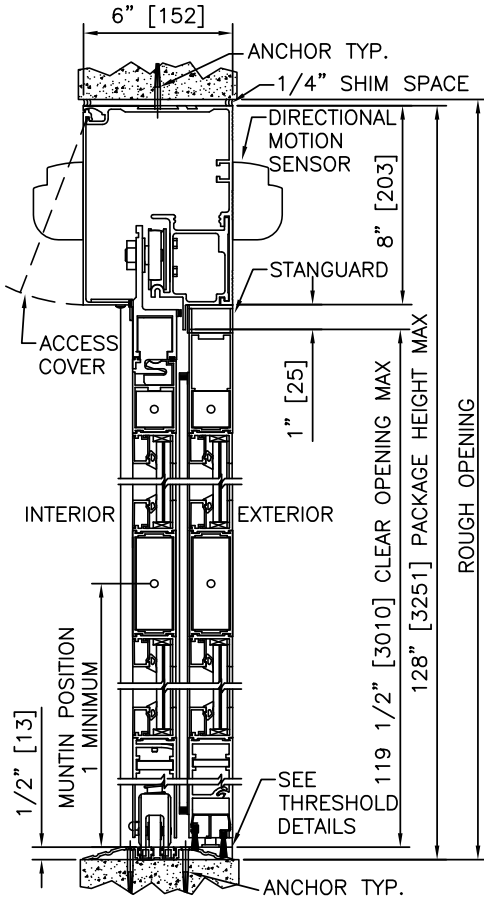

1 VERTICAL SECTION

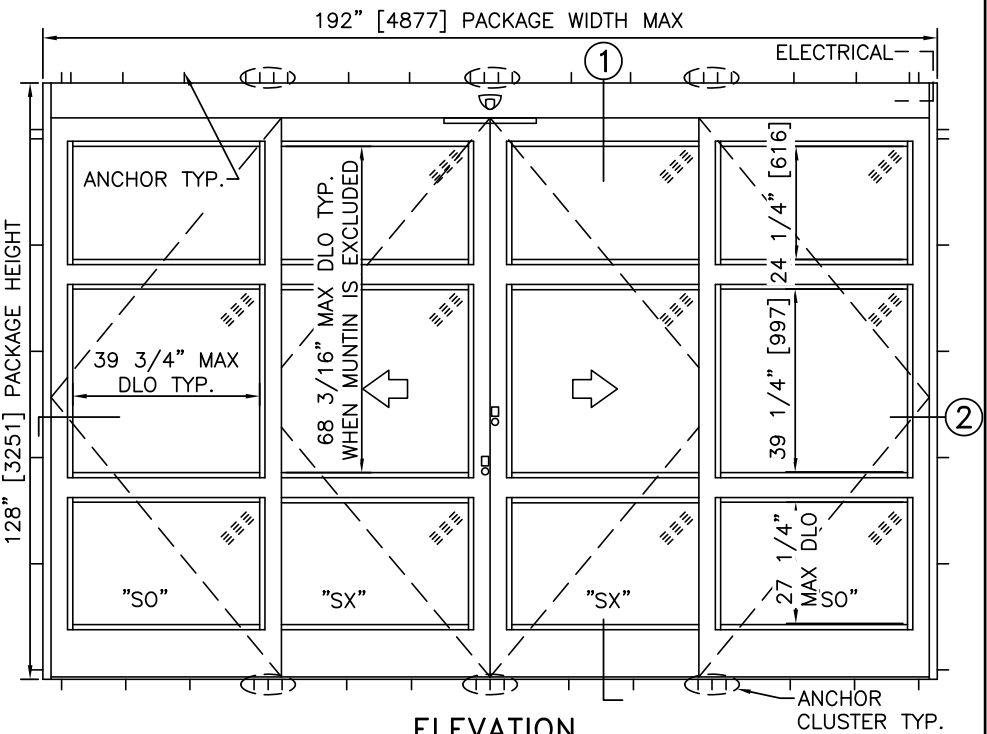

ELEVATION

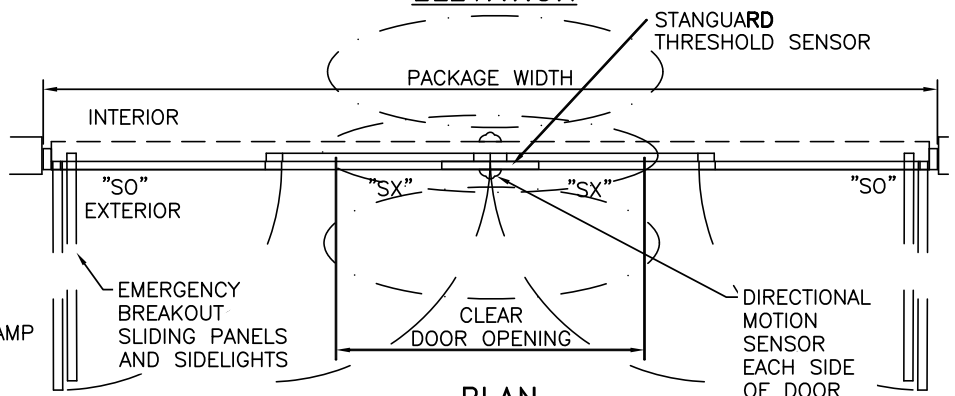

PLAN

- NOTES**
1. ELECTRICAL REQUIREMENTS: 120 VAC, 5 AMP MIN TO POWER OPERATOR BY ELECTRICAL CONTRACTOR.
  2. ROUGH OPENING SHALL PROVIDE 1/4" [6] SHIM SPACE ON SIDES AND TOP OF PACKAGE.
  3. ACTIVATION AND SAFETY ZONES ARE FOR REFERENCE ONLY; SEE ANSI/BHMA A156.10 FOR DETAILED REQUIREMENTS.
  4. PRODUCT SHALL BE MANUFACTURED AND INSTALLED IN ACCORDANCE WITH PRODUCT APPROVALS; SEE MIAMI-DADE COUNTY NOTICE OF ACCEPTANCE OR FLORIDA BUILDING CODE APPROVAL
  5. SEE SPECIFICATIONS FOR ADDITIONAL INFORMATION.

MAX. PACKAGE DIMENSIONS (MEDIUM STILE)				
PACKAGE WIDTH	NOMINAL CLEAR DOOR OPENING	DOOR PANEL NOMINAL WIDTH	EMERGENCY BREAKOUT NOM. WIDTH	PACKAGE HEIGHT MAX AT PACKAGE WIDTH
179.5"	72.0"	46.3"	162.0"	128.0"
192.0"	78.3"	49.4"	174.5"	104.0"

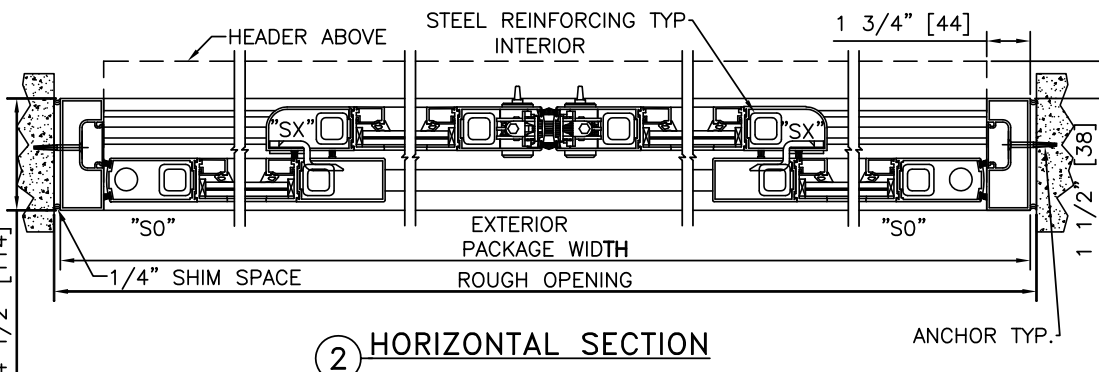

2 HORIZONTAL SECTION

DESIGN RATINGS	
MISSILE IMPACT RATING	
<input checked="" type="checkbox"/>	LARGE AND SMALL MISSILE IMPACT
DESIGN PRESSURE RATING (PSF [Pa])	
POSITIVE	55 PSF [2633 Pa]
NEGATIVE	55 PSF [2633 Pa]

## DURA-STORM 3000 IMPACT SERIES

BI-PARTING WITH AUTOMATIC LOCKING

PROJECT INFORMATION

PROJECT NAME:

LOCATION:

DOOR NUMBER(S):

DATE:

SHEET: OF

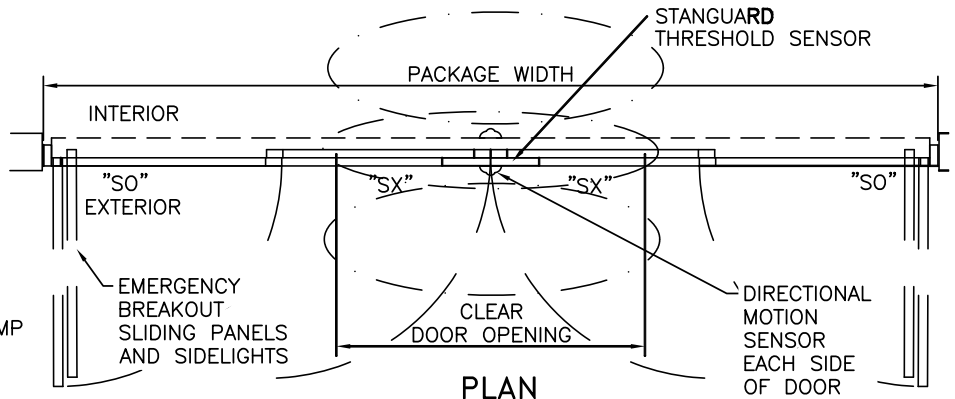
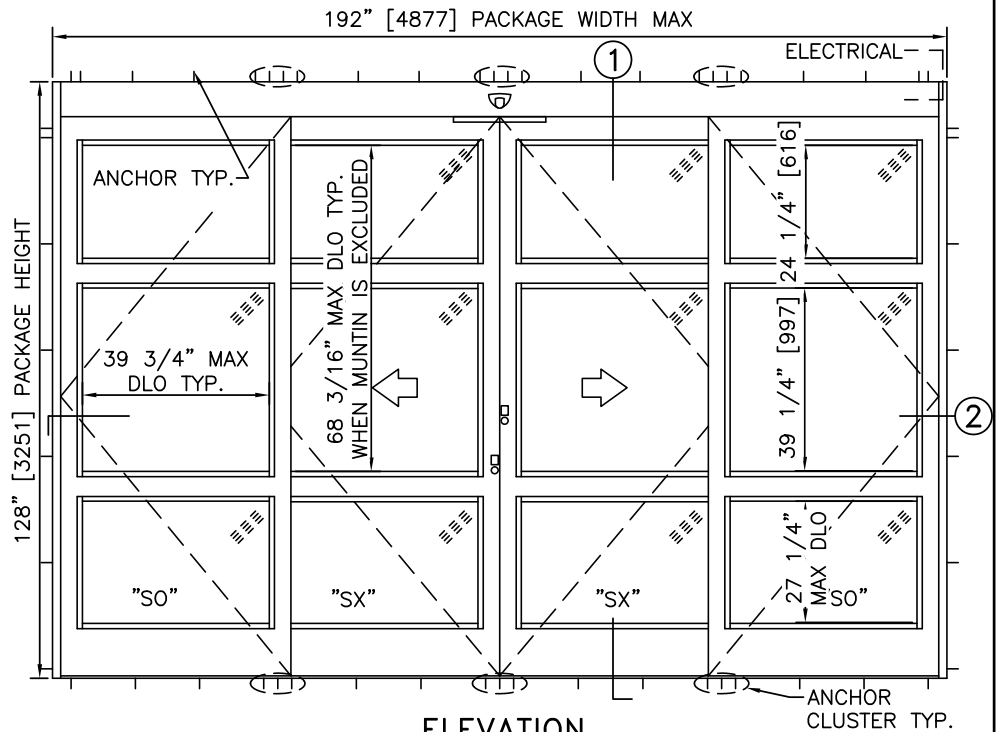
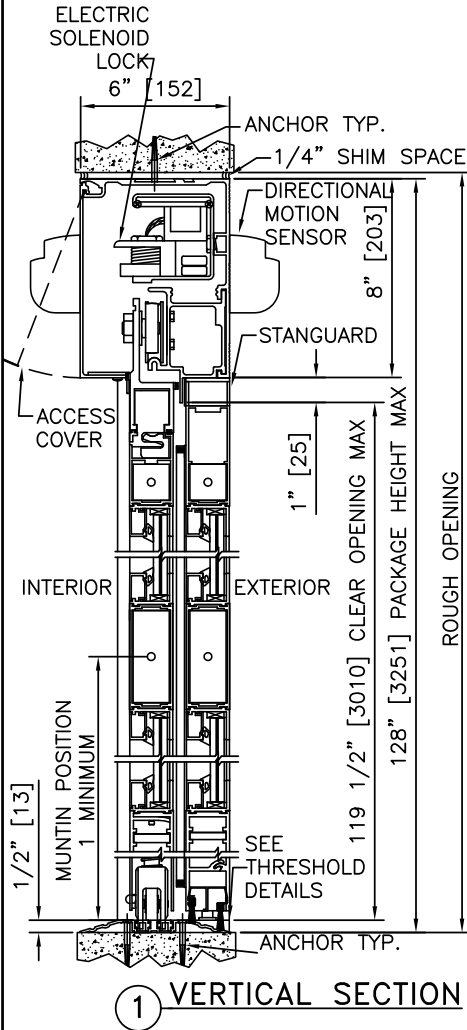

- NOTES**
1. ELECTRICAL REQUIREMENTS: 120 VAC, 5 AMP MIN TO POWER OPERATOR BY ELECTRICAL CONTRACTOR.
  2. ROUGH OPENING SHALL PROVIDE 1/4" [6] SHIM SPACE ON SIDES AND TOP OF PACKAGE.
  3. ACTIVATION AND SAFETY ZONES ARE FOR REFERENCE ONLY; SEE ANSI/BHMA A156.10 FOR DETAILED REQUIREMENTS.
  4. PRODUCT SHALL BE MANUFACTURED AND INSTALLED IN ACCORDANCE WITH PRODUCT APPROVALS; SEE MIAMI-DADE COUNTY NOTICE OF ACCEPTANCE OR FLORIDA BUILDING CODE APPROVAL
  5. SEE SPECIFICATIONS FOR ADDITIONAL INFORMATION.

MAX. PACKAGE DIMENSIONS (MEDIUM STILE)				
PACKAGE WIDTH	NOMINAL CLEAR DOOR OPENING	DOOR PANEL NOMINAL WIDTH	EMERGENCY BREAKOUT NOM. WIDTH	PACKAGE HEIGHT MAX AT PACKAGE WIDTH
179.5"	72.0"	46.3"	162.0"	128.0"
192.0"	78.3"	49.4"	174.5"	104.0"

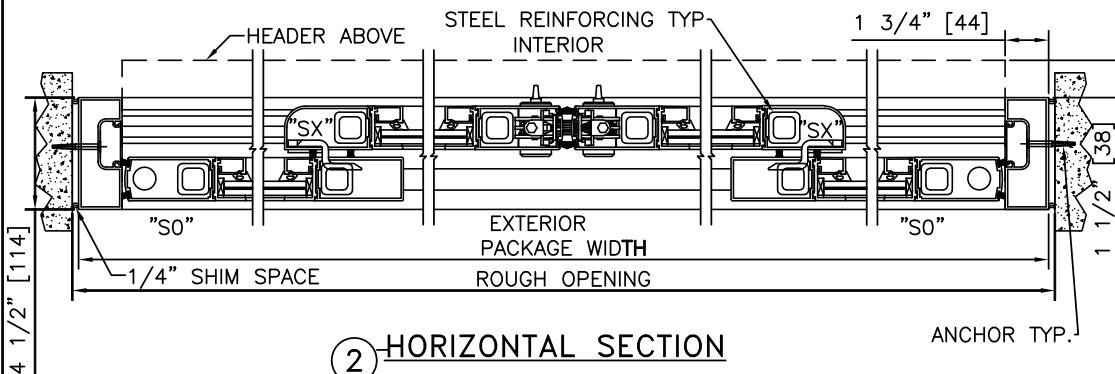

DESIGN RATINGS	
MISSILE IMPACT RATING	
<input checked="" type="checkbox"/>	LARGE AND SMALL MISSILE IMPACT
DESIGN PRESSURE RATING (PSF [Pa])	
POSITIVE	55 PSF [2633 Pa]
NEGATIVE	55 PSF [2633 Pa]